

NSTX

Spoked Lid/Flex/Cover Analysis

NSTX-CALC-12-08-00

Rev 0

May 2011

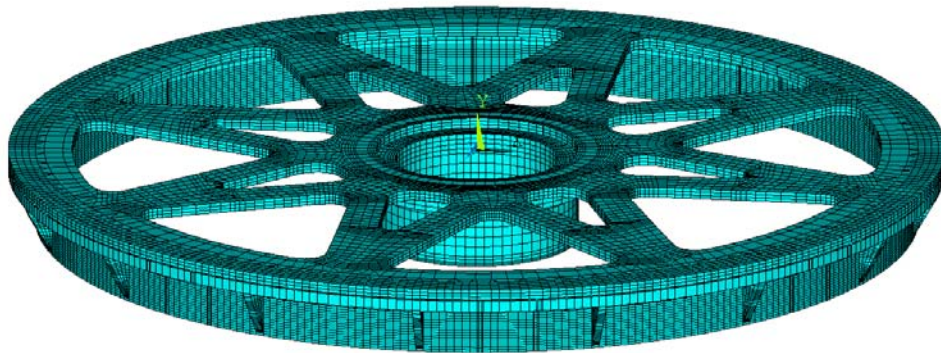

Prepared By:

Peter Titus, PPPL Mechanical Engineering

Reviewed By:

Irving Zatz

Approved By:

Mark Smith, NSTX Cognizant Engineer

PPPL Calculation Form

Calculation # **NSTX-CALC-12-08-00** Revision # 00 WP #, 1677
(ENG-032)

Purpose of Calculation: (Define why the calculation is being performed.)

The purpose of this calculation is to qualify the upper and lower lid assemblies. These assemblies bridge between the upper or lower rims of the umbrella structures to the inner TF flags. The upper lid must allow thermal growth of the TF inner leg as it heats up during a pulse. The flexing of the upper lid produces bending stresses. The global machine torques are carried across the upper and lower lids, and also produce bending stresses in the spokes in an orthogonal plane. The primary purpose of this calculation is to qualify the stresses in the lids and also to address the interfaces at the ID connection to the TF flags and the OD interface with the umbrella structure rims.

References (List any source of design information including computer program titles and revision levels.)

-See the reference list in the body of the calculation

Assumptions (Identify all assumptions made as part of this calculation.)

Halo loads do not load the upper lid because it is not directly connected to the upper end of the centerstack casing. Halo loads are assumed not load the lower spoked lid because the bent spokes are expected to be compliant enough laterally that neither halo loading from the passive plates or the lower end of the centerstack casing, will get beyond the stiffness of the pedistal or the stiffness of the vessel leg supports.

Calculation (Calculation is either documented here or attached)

Attached in the body of the calculation

Conclusion (Specify whether or not the purpose of the calculation was accomplished.)

The upper lid lies in a plane and resists the machine torques with only the small offset that results from the displacements of the TF. Stresses in the upper lid due to bake-out, normal operational heat up and extension of the TF, are also acceptable. The final design includes a rigid bolted connection at the rim of the umbrella structure - There is some possibility that the spokes could be thinned to reduce the stresses on the inner and outer bolt circle if needed.

The stresses in the lower lid are also acceptable . The lower spoked lid has been designed to be stiff enough to provide torsional registration of the lower centerstack/pedestal and the outer vessel structures, and protect the bellows from unacceptable motions.

Cognizant Engineer's printed name, signature, and date

Mark Smith _____

I have reviewed this calculation and, to my professional satisfaction, it is properly performed and correct.

Checker's printed name, signature, and date

Irving Zatz _____

1.2 Table of Contents

Title Page		1.0
ENG-33 form		1.1
Table of Contents		1.2
Executive Summary		1.2
Digital Coil Protection System Input		2.0
Design Input		3.0
References		3.1
Torsional Loading Input	3.2	
Criteria	3.3	
Drawing Excerpts		3.4
Solid Model Files	3.5	
Analyses		
Models	4.0	
Upper Spoked Lid Local Model Results	5.0	
Fixed Gusseted Outer Rim	5.1	
Frictional Effects of Sliding Umbrella Restraint blocks.	5.2	
Pinned Umbrella Restraint Blocks	5.2	
Bolted - Fixed Umbrella Restraint Blocks	5.3	
Bending Moments at the ID TF Collar - Possible Mitigation	5.4	
Lower Spoked Lid Local Model Results	6.0	
Loads and Moments on the TF Inner Leg Flag Collar	6.1	
Compliance and Stress Caused by Rotational Flexibility	6.2	
Global Model Results	7.0	
Bake Out Spoked Lid Stress	7.1	
Normal Operating Spoked Lid Stresses	7.2	
OOP Load Distribution with the FDR Spoked Lid Design	7.3	
Halo Current Loads	8.0	
Appendix A	Original Flex Plate Concept	
Appendix B	Added Ring Section	
Appendix C	Connection at the Inner Radius to the TF Collar (Reference 6 has Calculations of record)	

1.2 Executive Summary:

The purpose of this calculation is to qualify the upper and lower lid assemblies. These assemblies bridge between the upper or lower rims of the umbrella structures to the inner TF flags. The upper lid must allow thermal growth of the TF inner leg as it heats up during a pulse. The flexing of the upper lid produces bending stresses in the spokes as they flex.

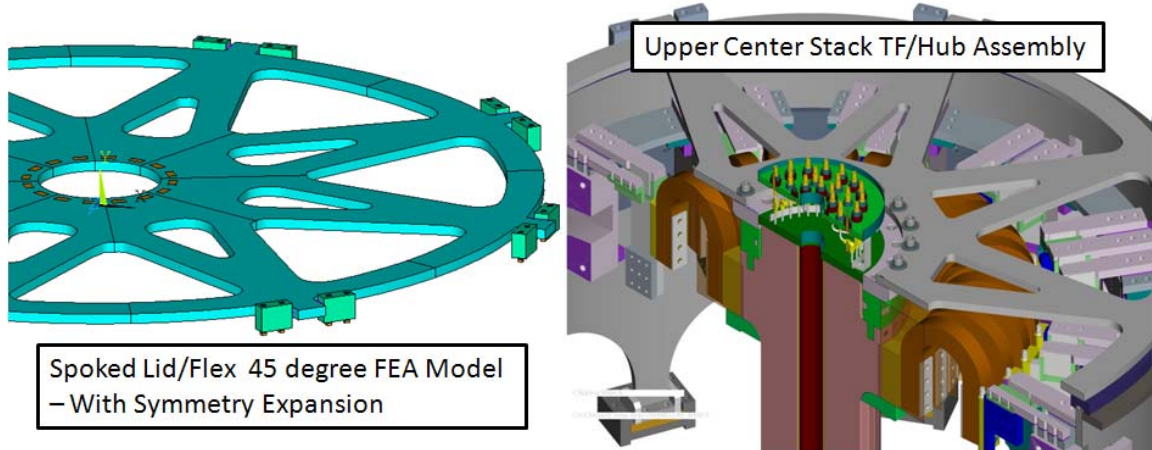

Figure 1.2-1 Earlier Upper Spoked Lid Model (left) and Machine Section (right)

One of the upper spoked lid models is shown in Figure 1.2-1. This had a pinned connection to cleats on the outer umbrella structure rim. The design shown at the May 2011 Peer Review is shown in Figure 1.2-1. This design employs a bolted fixed outer connection to a gusseted flange on the umbrella structure upper rim. This stiffer attachment increases the moments at the ID and OD and this is currently being investigated by A. Zolfaghari, ref 6. This stiffer lid also experiences larger stresses. The pinned design had a spoke stress of 17 ksi and the design with a fixed outer ring, has a peak stress of 36 ksi. There is some possibility that the spokes could be thinned to reduce the stresses on the inner and outer bolt circle if needed.

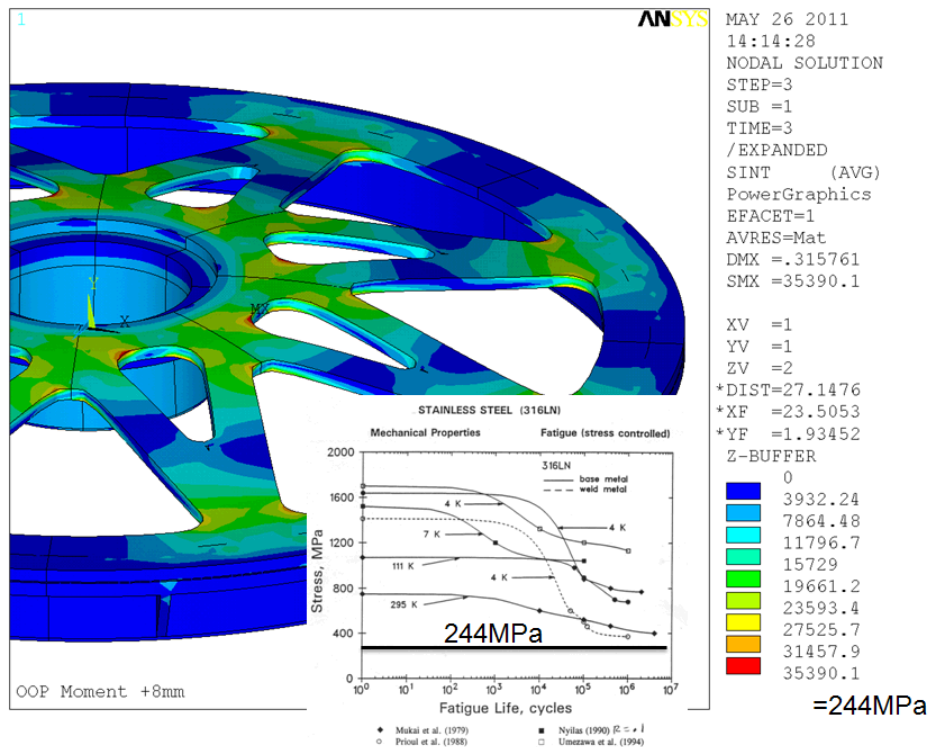

Figure 1.2-2 Upper Spoked Lid Stress with TF OOP Moment and Centerstack Expansion Displacement Imposed.

The advantage of the FDR design is that the OOP torques are transferred without reliance on any mechanism. The original NSTX had a cogged plate that slid vertically. Fit-up at the cogs was thought to have contributed to flag motion.

The global machine torques are carried across the upper and lower lids, and also produce bending stresses in the spokes in an orthogonal plane. The torque load path is redundant. The OOP torque load paths are similarly redundant on the bottom of the machine.

The upper lid lies in a plane and resists the machine torques with the small offset that results from the displacements of the TF. Stresses in the upper lid due to bake-out, normal operational heat up and extension of the TF, are also acceptable.

The stresses in the lower lid are also acceptable. The compliance of the bent spokes caused torques and lateral loads to be taken by other structures. There was a concern that having such a compliant member connecting the centerstack to the umbrella structure could introduce relative displacements and loads at the bellows. A flat concept was developed and it is the present FDR design approach.

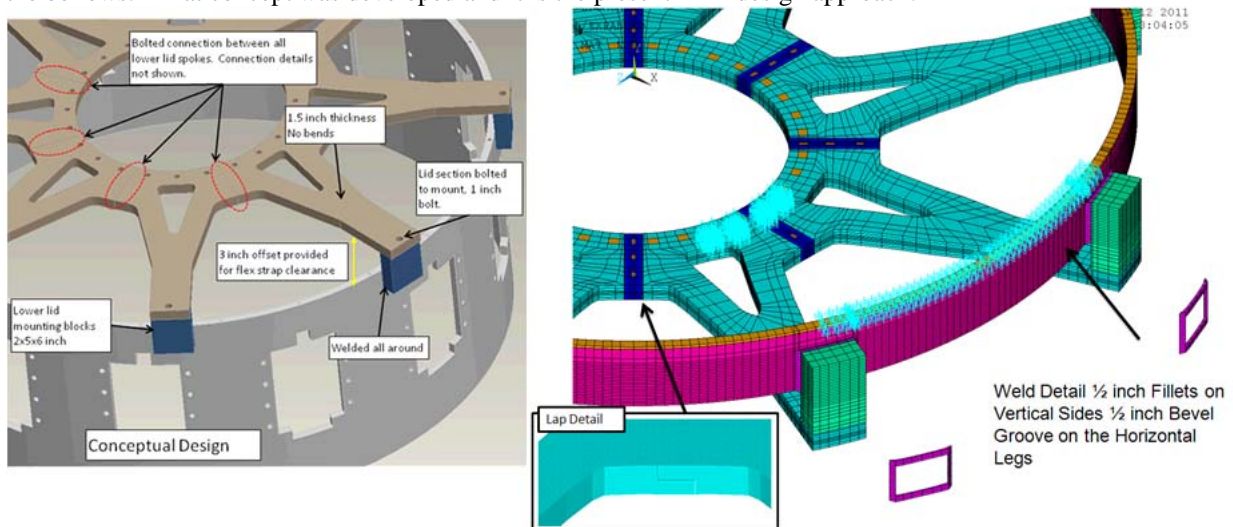

Figure 1.2-2 Flat Lower Spoked Lid Design Inverted for Clarity (Left) Analysis Model (Right)

Different design philosophies are used for the upper and lower lids. The upper lid is the primary torque transmission mechanism between the umbrella structure and the top of the TF flags. A secondary path of the machine OOP torque, goes from the outer vessel, through the dome or dished head, through the ceramic break, then across the bellows [7] and into the centerstack casing.

The lower lid shares a part of three load paths that carry torque. The first is the spoked lid. The second is the bellows connection between vessel the centerstack casing. These are the load paths used for the upper structures, but the lower torque is also carried by a third load path through the pedestal to the floor and up through the braced vessel support columns to the vessel.

Designs have evolved from the CDR to the FDR. The lower torque load paths have shifted from the lid to the floor. This allows a significant increase in access from below the machine.

The interfaces at the ID connection to the TF flags is addressed by reference [6]. The OD

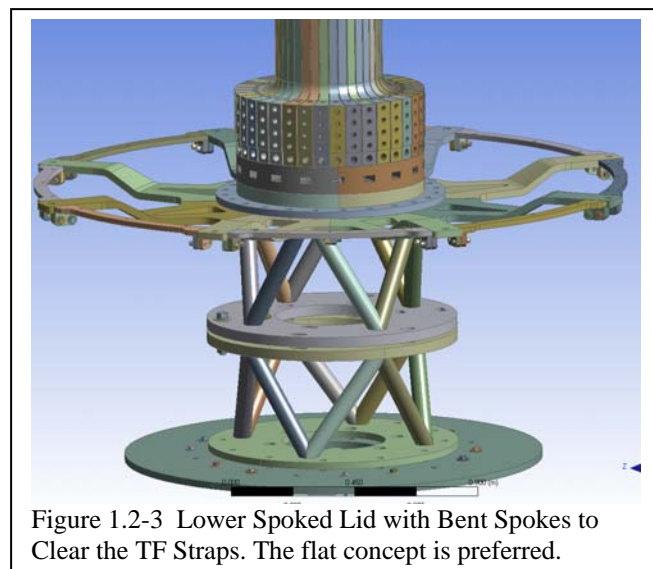

Figure 1.2-3 Lower Spoked Lid with Bent Spokes to Clear the TF Straps. The flat concept is preferred.

interface with the umbrella structure rims is addressed in this calculation

This calculation follows the torque being carried through the upper umbrella structure rim, across the lid assembly and to the upper TF flags [6]. The torque carried in this load path is quantified in the global model described in ref[1]. The inner TF flags and collar also carry this torque, and interface with the spoked lid. The lid also must allow the vertical growth of the TF inner legs.

The torsional moment for design of the lid/flex/Diaphragm bolting and the TF steps or keys from ref [1] is 0.3MN-m for the lower lid (Figure 3.2-1) and 0.25 MN-m for the upper lid from ref [1]). This is the torque being transmitted from the centerstack TF to the outer rim of the umbrella structure This was translated into a load per TF flag of about 7000 lbs.

Loads resulting from centerstack halo currents produce a lateral load and a moment. at the lower connections to the pedestal. The bent spoked lid will transmit a minimal amount of this load to the umbrella structure because of the compliance of the bent spokes. The upper Halo current load inventory goes through the upper bellows to the vessel and not the spoked lid. This effect is addressed in bellows [7] and Centerstack casing calculations. This is included in the lid analysis via the 9000 lb load (the OOP torque load is around 7000 lbs). The lower centerstack Halo current load inventory goes through the skirt to the lower TF flag teeth/pins and splits between the pedestal and to the lower lid to the outer vessel leg supports. The lower TF G-10 collar must take the torques and centerstack halo loads - and (OH + PF1,abU&L) launching loads. Halo loads on the vessel and passive plates may go through the lower spoked lid being shared by the vessel support legs and the pedestal. The spoked lid bolts were checked for the full loading from the GRD specification of 700,000 amps across the face of the passive plates. This full load inventory is not expected to be applied to the lid - most will appear in the vessel support legs and reduced by the inertia of the tokamak.

The global model described in reference [1] was updated with the lower pedestal and spoked lid designs. This provides a means to qualify the stresses in the spoked lid, but the main purpose of including the lid in the global model is to address the need for torsional stiffness or compliance of the plate to ensure that the inner leg torsional shear stress is acceptable with the FDR configurations. The concern comes from the relative compliance of the bent spokes in the lower lid. Figure 4.0-2 shows the global model of the tokamak including the upper and lower spoked Lid

The hub/collar section is as Mark Smith, and Jim Chrzanowski has designed - with only preloaded bolts and friction connecting the spoke/lid to the collar in torsion. Since the moment caused by the 8mm expansion of the centerstack appears to impose minimal stresses on the collar, the outer lugs that connect to the umbrella structure flange can be pinned connections. The vertical growth can be absorbed by flexure of the spoked lid - and a little flexure of the collar. Ali preloaded the 18 bolts to 50000 lbs each.

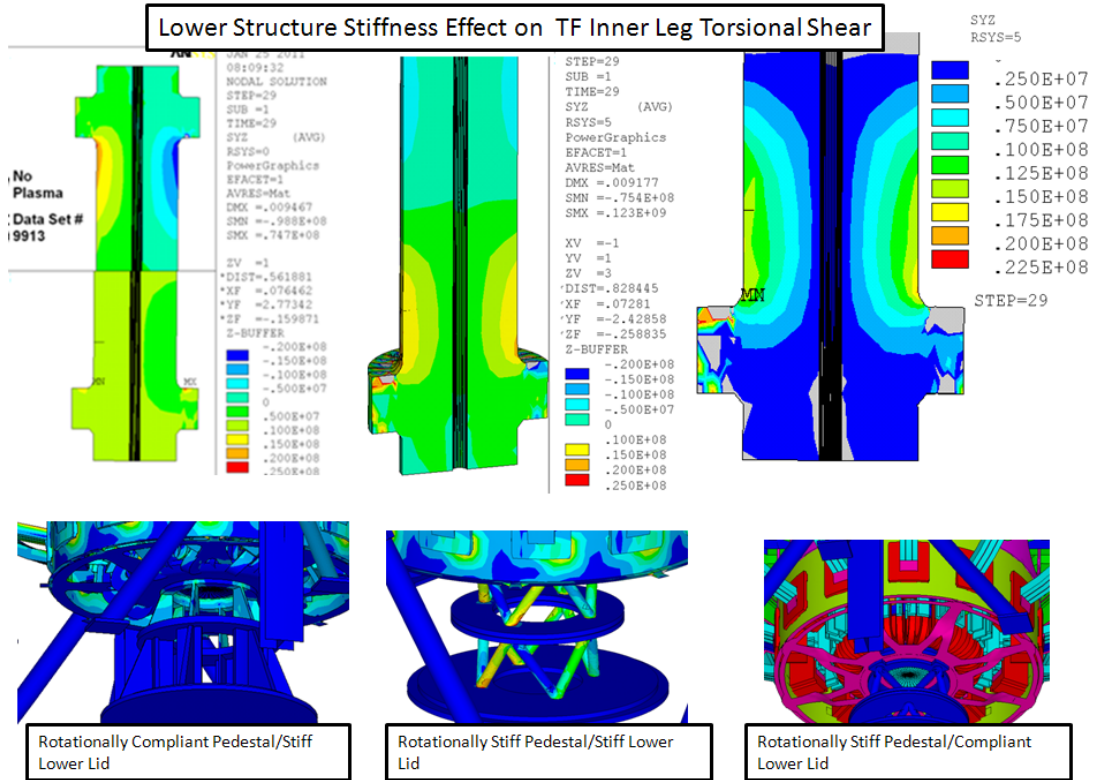

The FDR chosen design for the lower lid is a flat, relatively stiff spoked "wheel". This was chosen over the bent spoke design which was too compliant to protect the bellows from relative motions and lateral loads from halo loading and from global machine TF OOP loading. Figure 1.2-4 shows the load path between inner and outer vessel structures that would result from a weak lower lid.

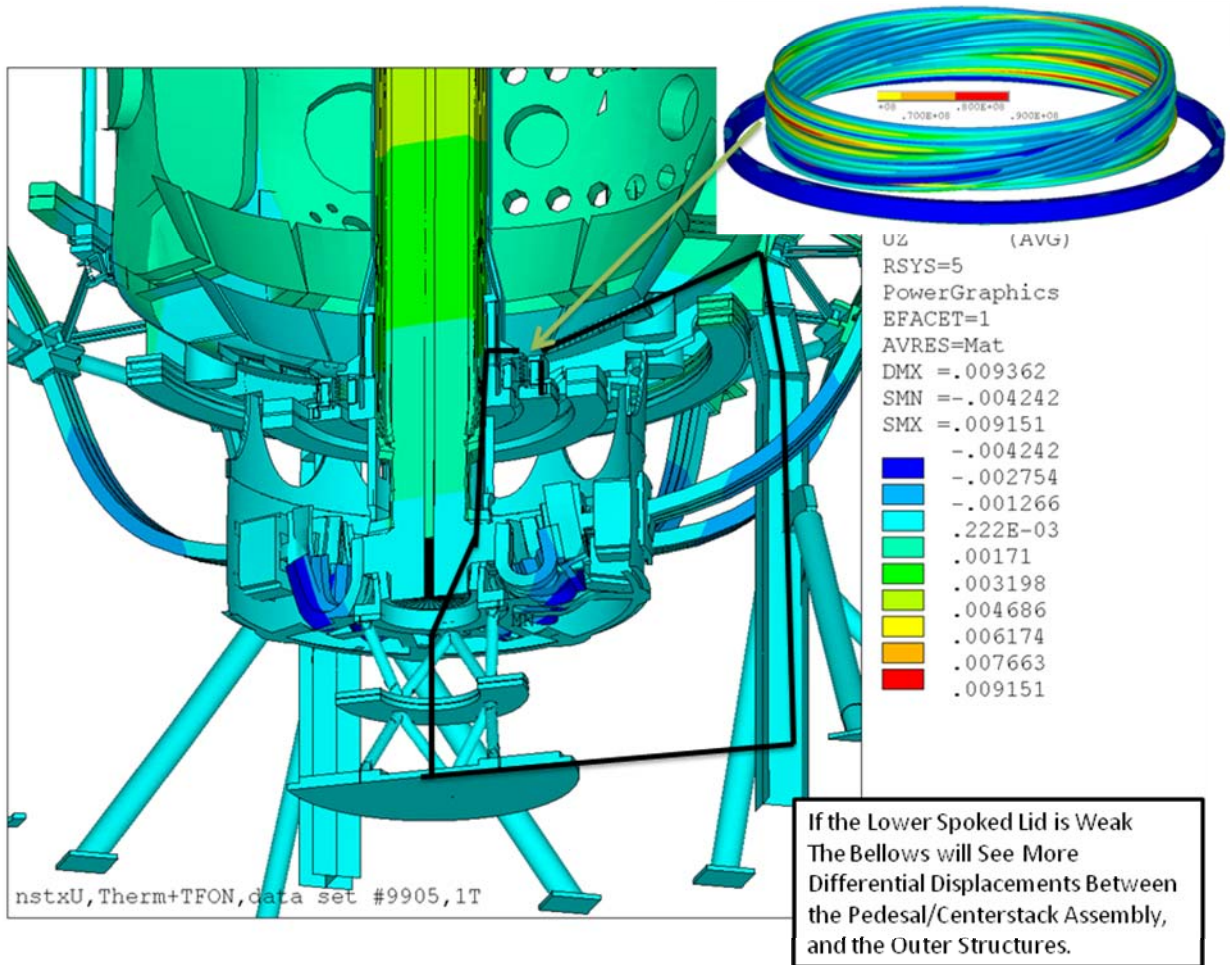

Figure 1.2-4 Structural Effect of a Laterally and Torsionally Compliant Lower Lid on the Bellows

Bend spoke lower lid analysis results were shown at the May 11 2011 Wednesday project meeting based on models with the Vee pipe pedestal and the bent spoked lid. These two taken together behave differently than the CDR and PDR designs. The load path - exclusive of the spoked lid - for torsional and lateral loads - is shown with a dark line in the figure above. With the stiff pedestal and the softer lid, the bellows connection between the centerstack and the vessel will see more displacements. Jon Menard picked up on this and expressed a concern that this is a vacuum boundary and a problem here might affect the reliability of the machine. The net vacuum side load is included in the global model simulation. In the global model, the torsional stiffnesses are reasonably represented. None of the bellows stresses were troublesome - The torsional shear is higher these would have required a revision to Pete Rogoff's bellows calc. - and Len Myatt's treatment of the ceramic break. The uncertain effect of the halo loading from the passive plates would require a more careful treatment if the lateral load path to the pedestal was compliant.

2.0 DCPS Algorithm

The load used in the analysis was based on the maximum torsional shear load being transferred through the crown to the lid, for all the 96 scenarios. This number is actually 7400 lbs (Ref 1, section 8.19). This was rounded up to 9000 lbs for design. and to allow for the 10% headroom for PF currents and to allow some headroom for halo current loads. The torsional moment at the TF collar teeth/pins will scale with the calculated torsional shear stress in the TF coil at the turn radius. For the 96 scenarios, this is 24 MPa. (ref 4). Spoked lid stresses should be scaled based on the TF torsional shear stress calculated for the DCPS

3.0 Design Input

3.1 References

- [1] NSTX-CALC-13-001-00 Rev 1 Global Model – Model Description, Mesh Generation, Results, Peter H. Titus December 2010
- [2] NSTX Structural Design Criteria Document, I. Zatz
- [3] NSTX Design Point June 2010 http://www.pppl.gov/~neumeyer/NSTX_CSU/Design_Point.html
- [4] NSTX-CALC-13-04-00 Rev 0 DCPS Inner leg torsional shear Stress, P.H.Titus, R.Woolley
- [5] <http://www.esk.com/en/products-brands/products/frictional-connection-elements/friction-enhancing-metal-shims.html>
- [6] Structural Calculation of the TF Flag Key, NSTXU-CALC-132-08-00 , A. Zolfaghari
- [7] Center Stack Casing Bellows, NSTXU-CALC-133-10-0 by Peter Rogoff.
- [8] NSTX Upgrade DISRUPTION ANALYSIS OF PASSIVE PLATES, VACUUM VESSEL AND COMPONENTS mNSTXU-CALC-12-01-01Rev 1 April , 2011 Peter Titus
- [9] Email from Art Brooks Thu 3/11/2010 8:21 AM, providing Upper and Lower design loads for the centerstack casing halo loads, copy of the email is included in the appendices

3.2 Torsional shear loading on the bolt circles and the TF steps, pockets or keys

The torsional load from the lid/flex/diaphragm is transmitted to a toothed collar that engages the torsional load from the TF inner leg. In the present design the TF flags are staggered to engage a G-10 ring that is then bolted to the flex/lid. The keyed connection of the G-10 ring appears to have a larger capacity to carry torque than the bolt circle. Maybe shear keys or pins should be added here as well To calculate the torsional moment being transmitted across the lid/flex, the torsional shear stress in the solid element portion of the model is post-processed using the ANSYS time history post-processor, Post26. All thermal cases and the 96 scenarios shear stress results are then used to compute the moment within post 26. The moment is then plotted.

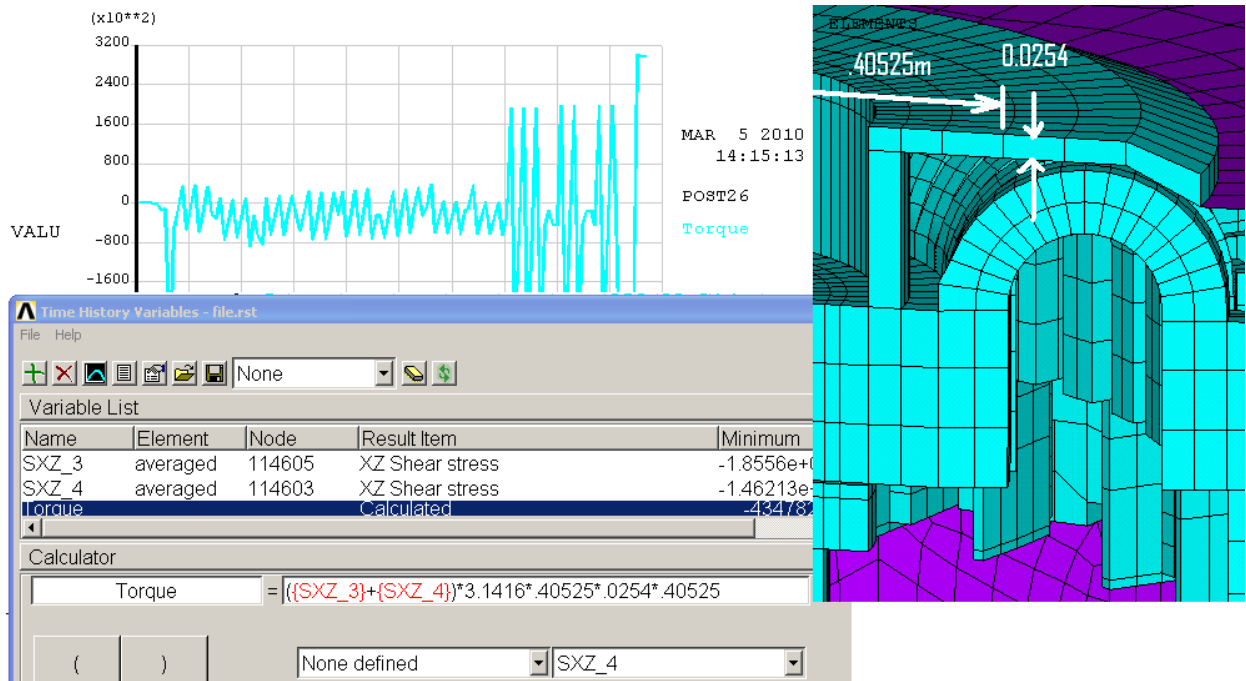

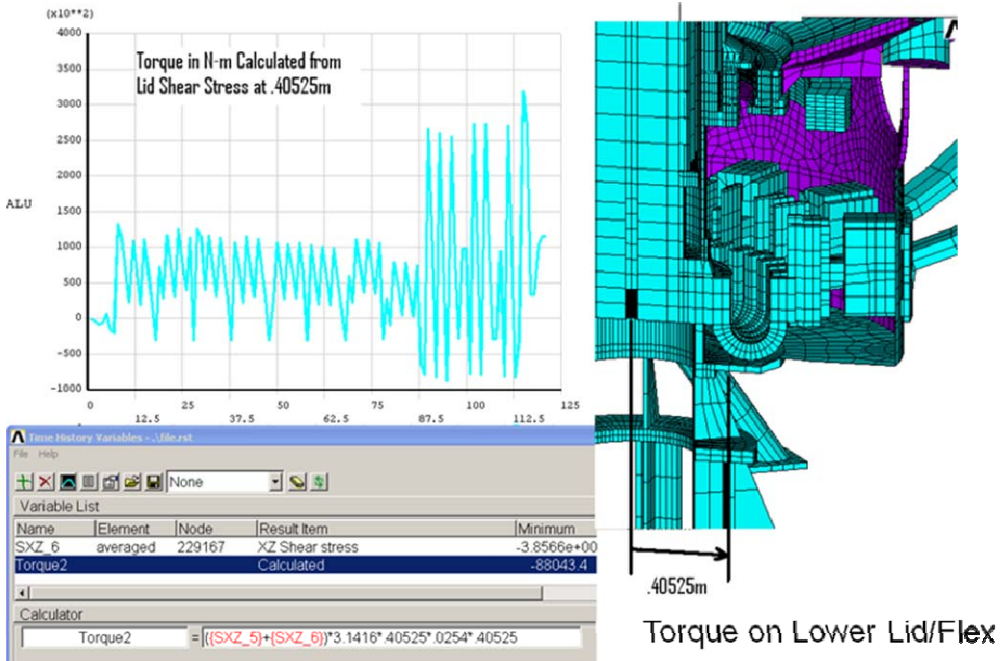

Figure 3.2-1 Torque at the Lower Lid, from ref [1]

The torsional moment for design of the lid/flex/diaphragm bolting and the TF steps or keys is 0.28MN-m for the lower lid – With Holes -Only slightly less than without.

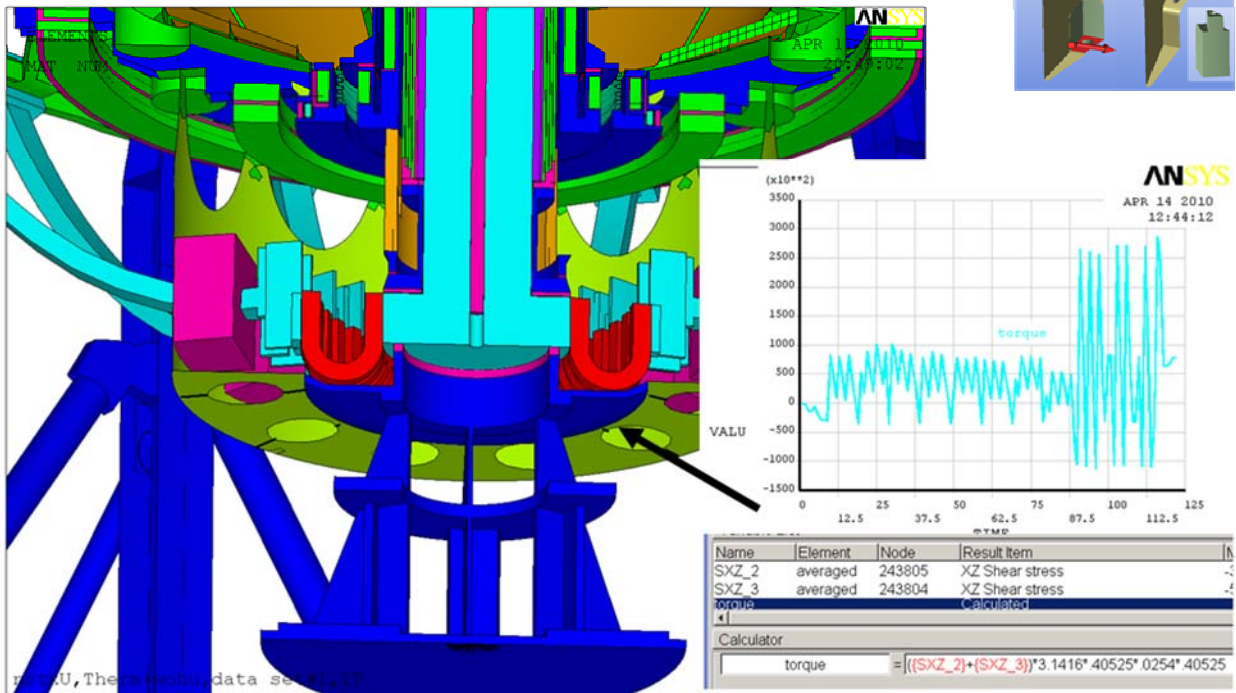
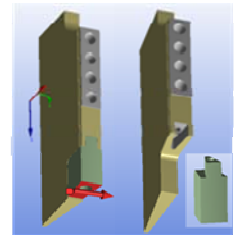

Figure 3.2-2 Torque at the Lower Lid with Circular Access Openings

3.3 Materials and Allowables

Table 3.3-1 Tensile Properties for Stainless Steels

Material	Yield, 292 deg K (MPa)	Ultimate, 292 deg K (MPa)
316 LN SST	275.8[7]	613[7]
316 LN SST Weld	324[7]	482[7] 553[7]
316 SST Sheet Annealed	275[8]	596[8]
316 SST Plate Annealed		579
304 Stainless Steel (Bar, annealed)	234 33.6ksi	640 93ksi
304 SST 50% CW	1089	1241 180ksi

Table 3.3-2 Coil Structure Room Temperature (292 K) Maximum Allowable Stresses, S_m = lesser of 1/3 ultimate or 2/3 yield, and bending allowable = $1.5 \cdot S_m$

Material	S_m	$1.5S_m$
316 Stainless Steel	184	276
316 Weld	161	241
304 Stainless Steel (Bar, annealed)	156MPa(22.6ksi)	234 MPa (33.9ksi)

ASTM A193 Bolt Specs from PortlandBolt.com

B8M	Class 1 Stainless steel, AISI 316, carbide solution treated.
B8	Class 2 Stainless steel, AISI 304, carbide solution treated, strain hardened
B8M	Class 2 Stainless steel, AISI 316, carbide solution treated, strain hardened

Mechanical Properties

Grade	Size	Tensile ksi, min	Yield, ksi, min	Elong, %, min	RA % min
B8 Class 1	All	75	30	30	50
B8M Class 1	All	75	30	30	50
B8 Class 2	Up to 3/4	125	100	12	35
	7/8 - 1	115	80	15	35
	1-1/8 - 1-1/4	105	65	20	35
	1-3/8 - 1-1/2	100	50	28	45
B8M Class 2	Up to 3/4	110	95	15	45
	7/8 - 1	100	80	20	45
	1-1/8 - 1-1/4	95	65	25	45
	1-3/8 - 1-1/2	90	50	30	45

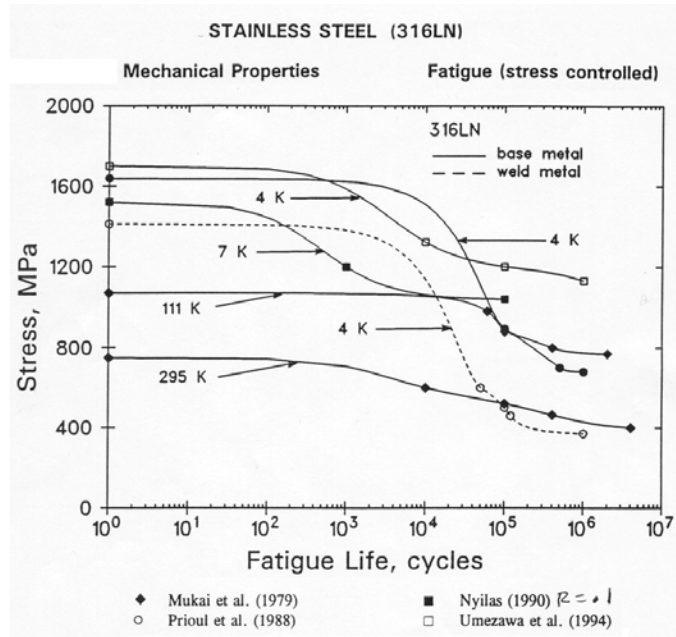

Figure 7.0-3 Fatigue S-N Curve for 316 Stainless Steel

3.4 Drawings, Screenshots of the Designs

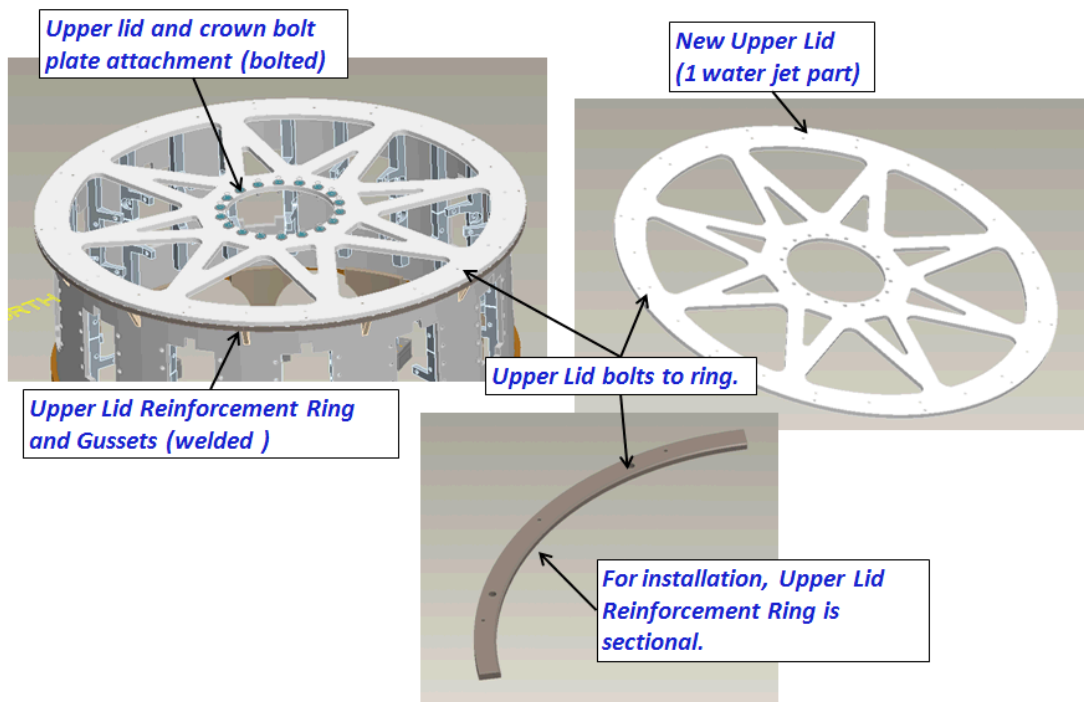

Figure 3.4-1 Upper Spoked Lid Details from Mark Smith's May 2011 Peer Review Presentation

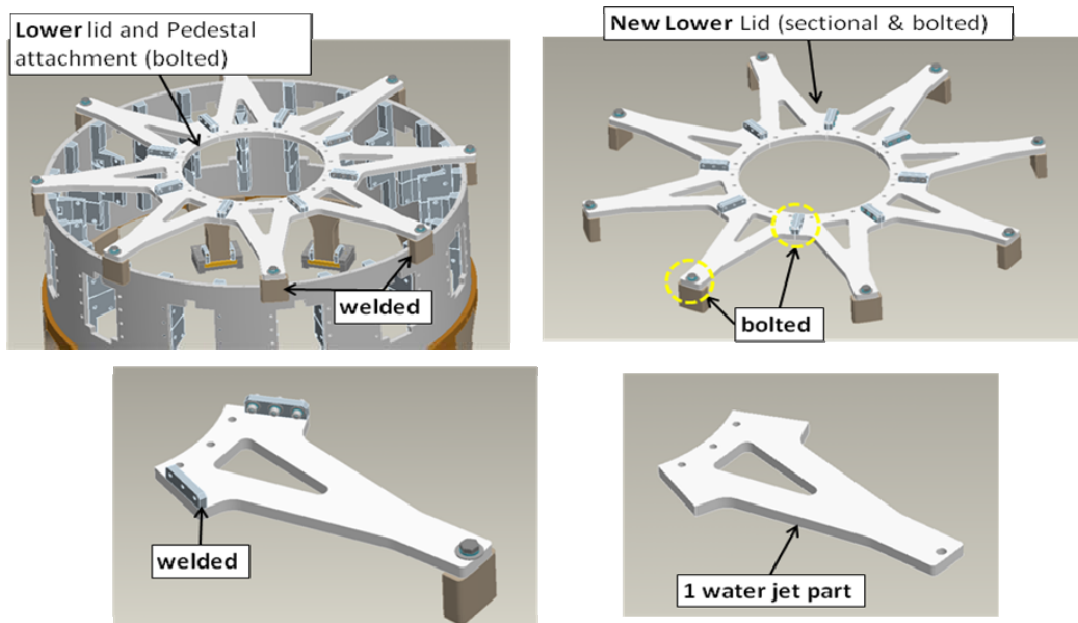

Figure 3.4-2 Lower Spoked Lid Details from Mark Smith's May 2011 Peer Review Presentation

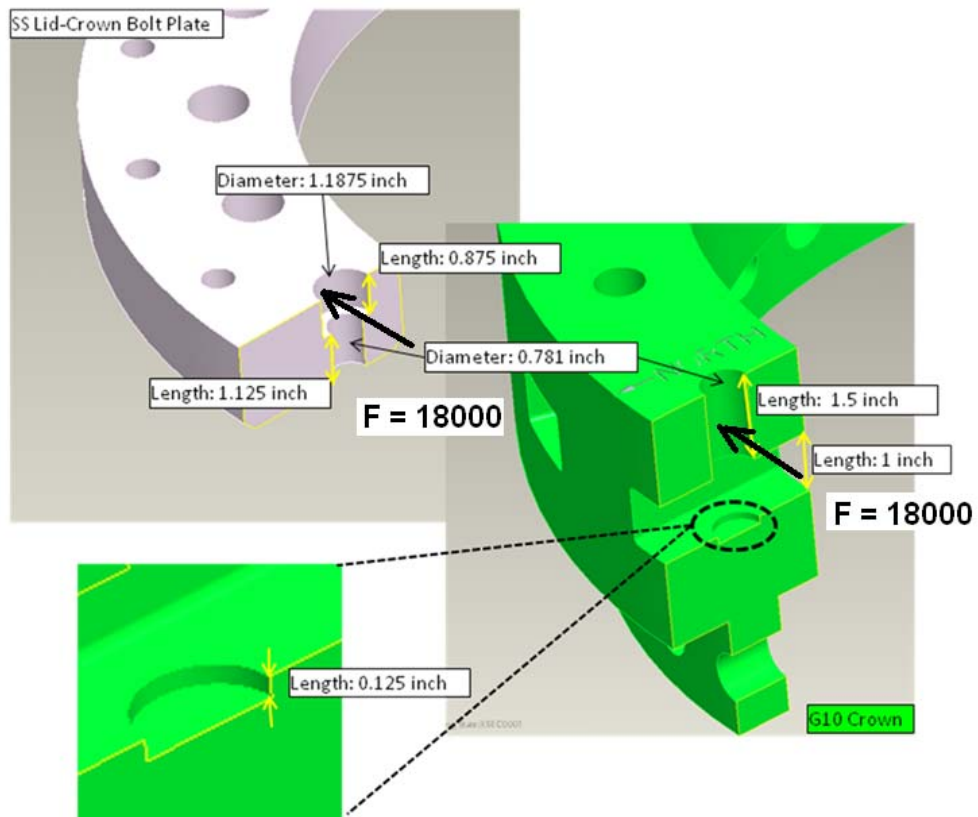

Figure 3.4-3 Early Details of the Spoked Lid to TF flag Collar

4.0 Analysis Models

Two types of models are used to qualify the spoked lid assemblies. Separate models of the "wheel" are used with torsional loads and centerstack expansion displacements applied. The torques are derived from the global analysis[1]. Initial loads were derived from global analysis model that had a full thin flex plate. This is shown in Appendix A. As of May 2011, the spoke geometries are modeled consistent with the FDR design of the spoked lids. Shown in this section are plots and descriptions of both the local or separate models and the global model which includes the latest (as of May 2011) geometry.

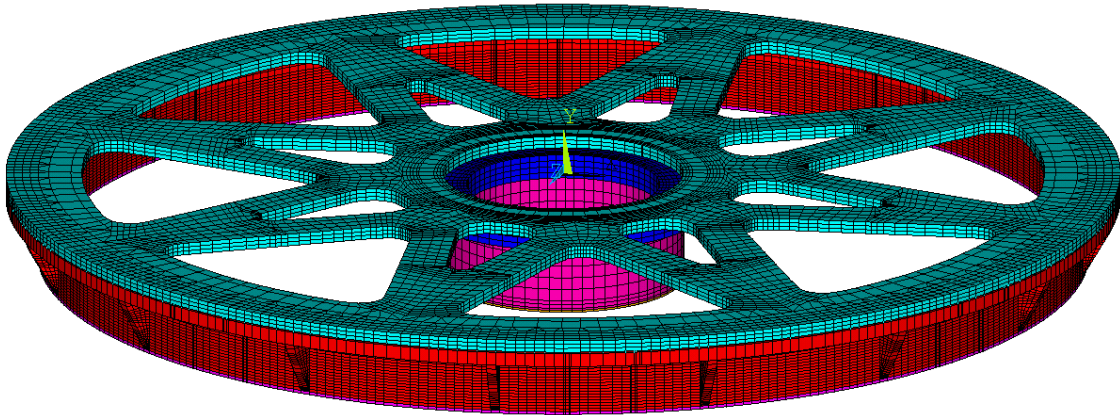

Figure 4.0-1 Symmetry Expansion of the Bolted Outer Flange Design.

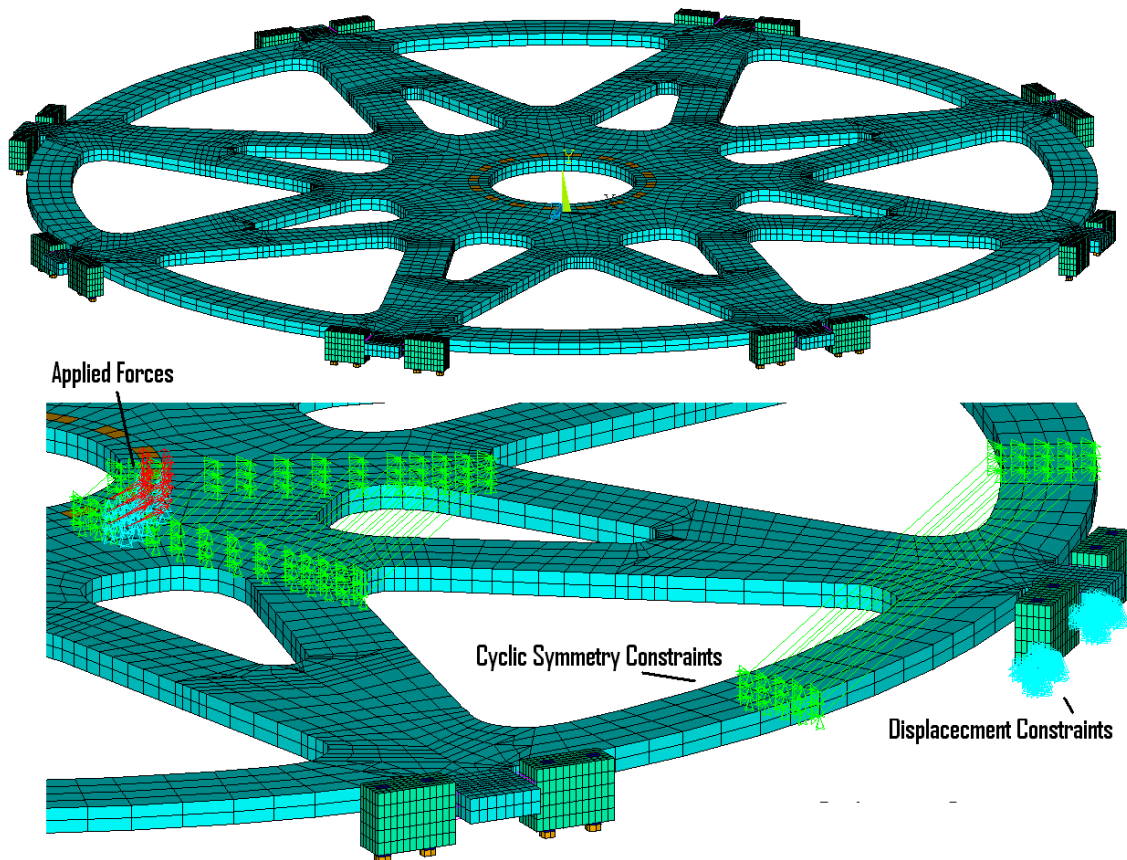

Figure 4.0-2 Local Model of the Upper Spoked Lid - Outer Lug Restraint Design. This is also a symmetry expansion with the symmetry coupling shown

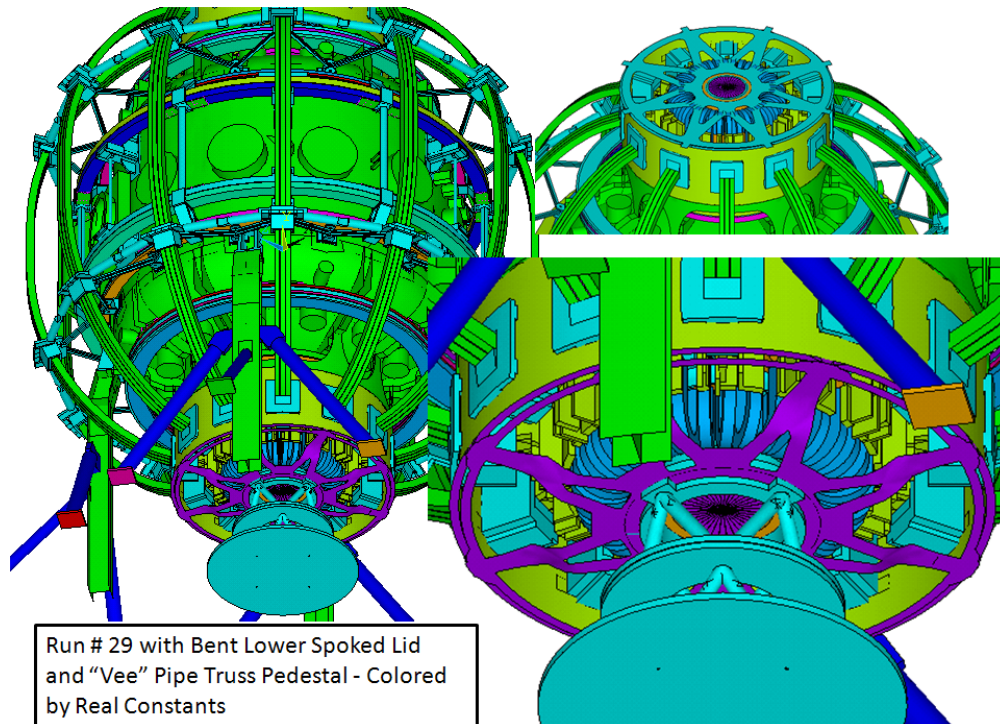

Figure 4.0-3 Global Model of the Tokamak showing the Upper and Lower Spoked Lids. In this model, the Lower "Bent" lid is shown.

5.0 Upper Spoked Lid

The spoked lid or flex plate must allow the relative motions of the central column which is fixed vertically at the lower end by connections to the pedestal and to the lower TF flag extensions. The upper connections between the outer rim of the umbrella structure and the TF flags must allow the full vertical expansion of the central column. This is 9 mm at the elevation of the connection. The lid/flex plate is intended to bend and absorb the vertical motions elastically. Bending stresses develop at the ID and OD of the plate which produce prying moments at the bolt circles.

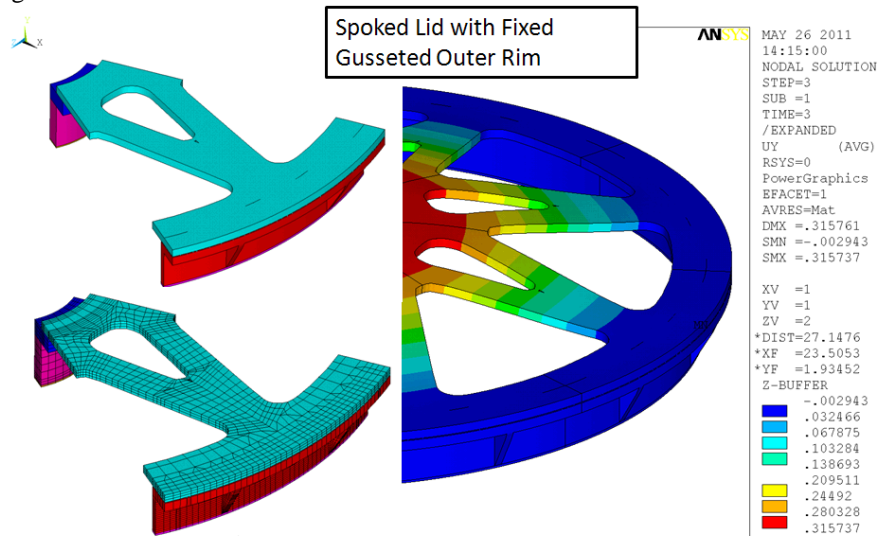

Figure 5.0-1 FDR Design Upper Lid Model

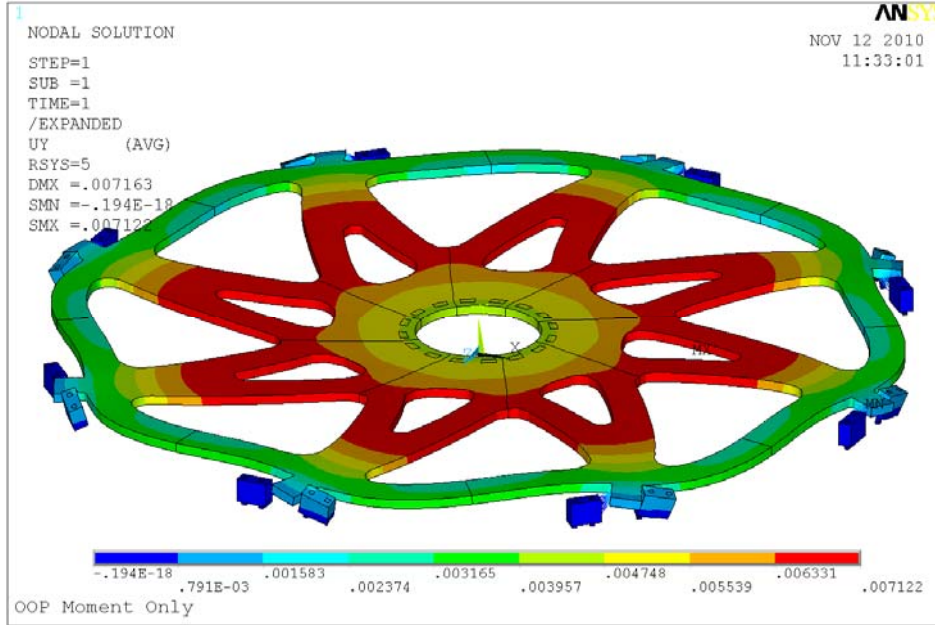

Figure 5.0-2 Pinned Outer Lug Model

5.1 Spoked Lid with Bolted Fixed and Gusseted Outer Flange.

This is close to the CDR configuration with bolt circles at the ID and OD of the lid. Vertical growth of the centerstack is accommodated by elastic flexure of the spokes.

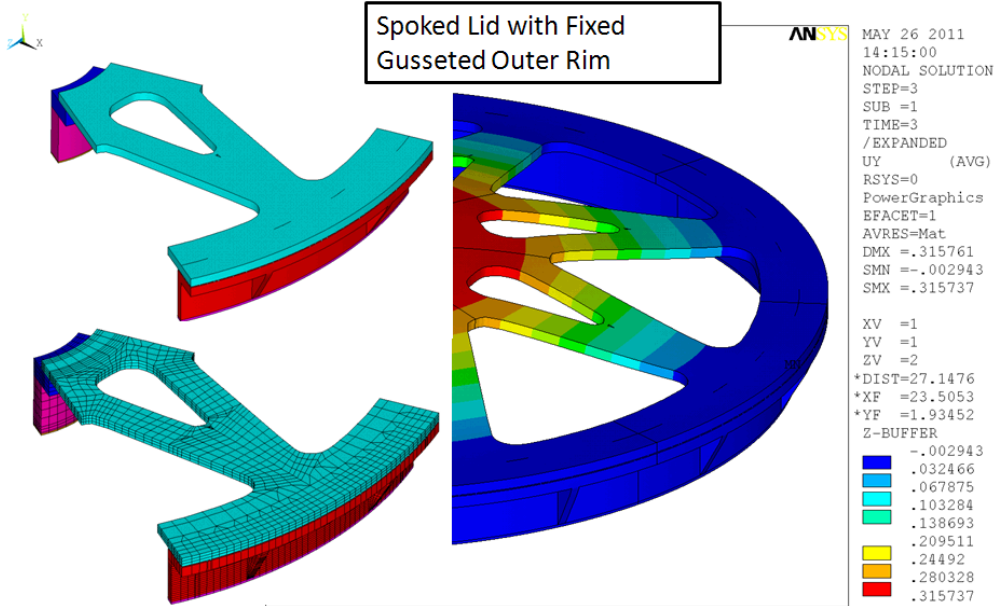

Figure 5.1-1 Spoked Lid with Bolted Outer Flange

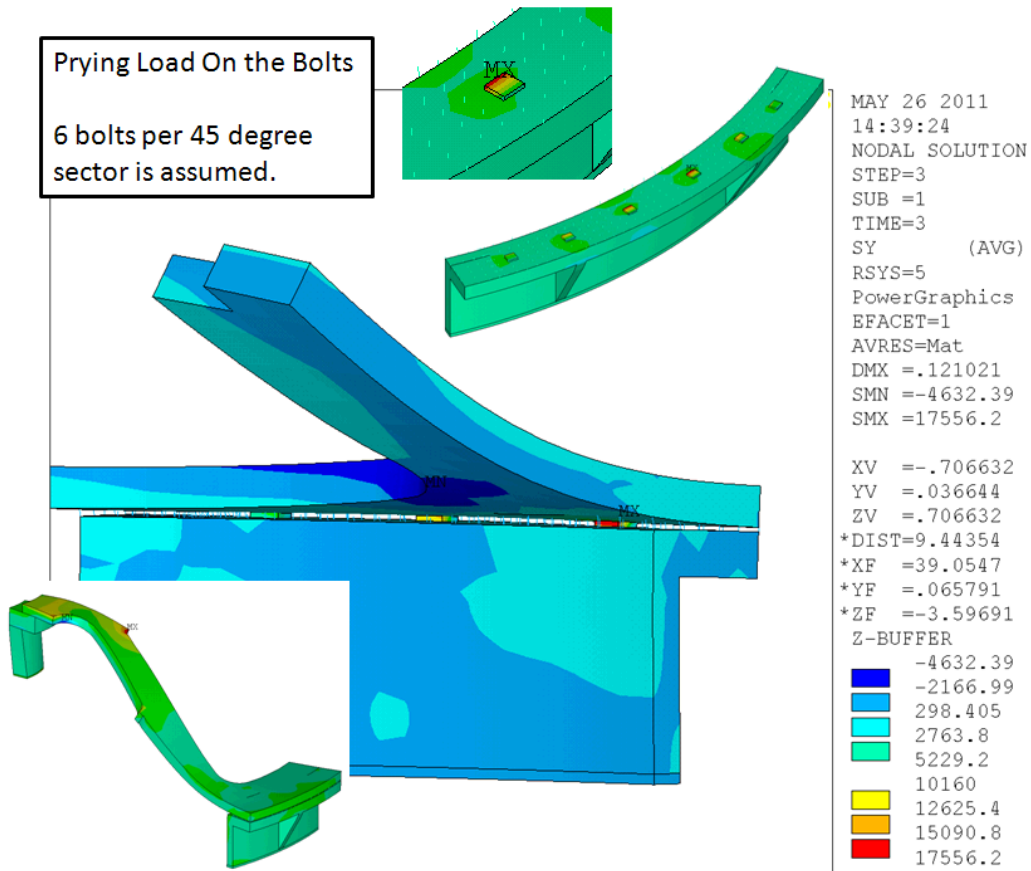

Figure 5.1-2 Spoked Lid with Bolted Outer Flange

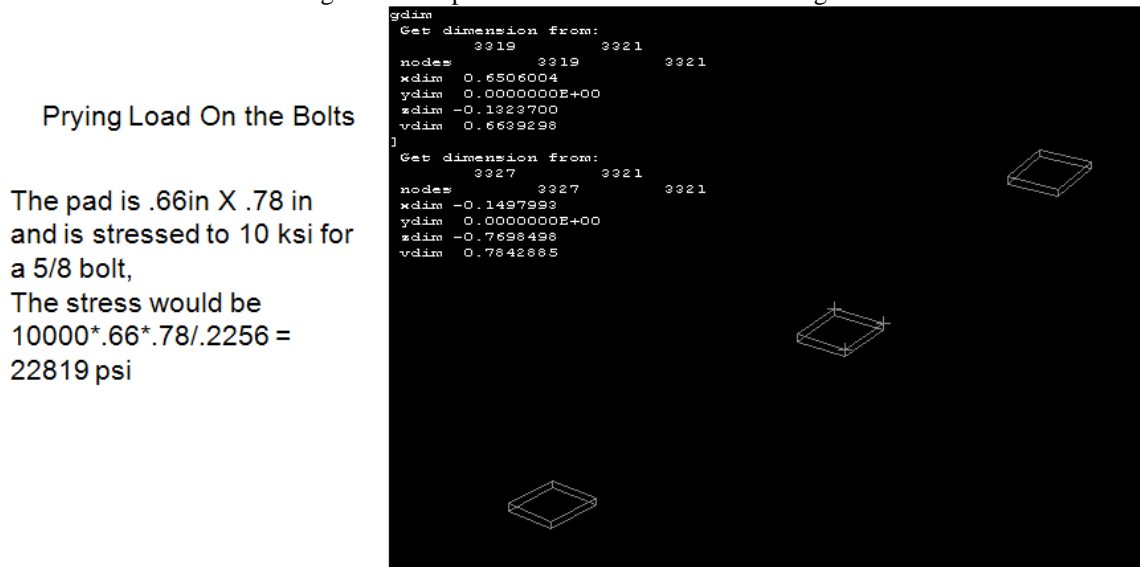

Figure 5.1-3 Spoked Lid with Bolted Outer Flange

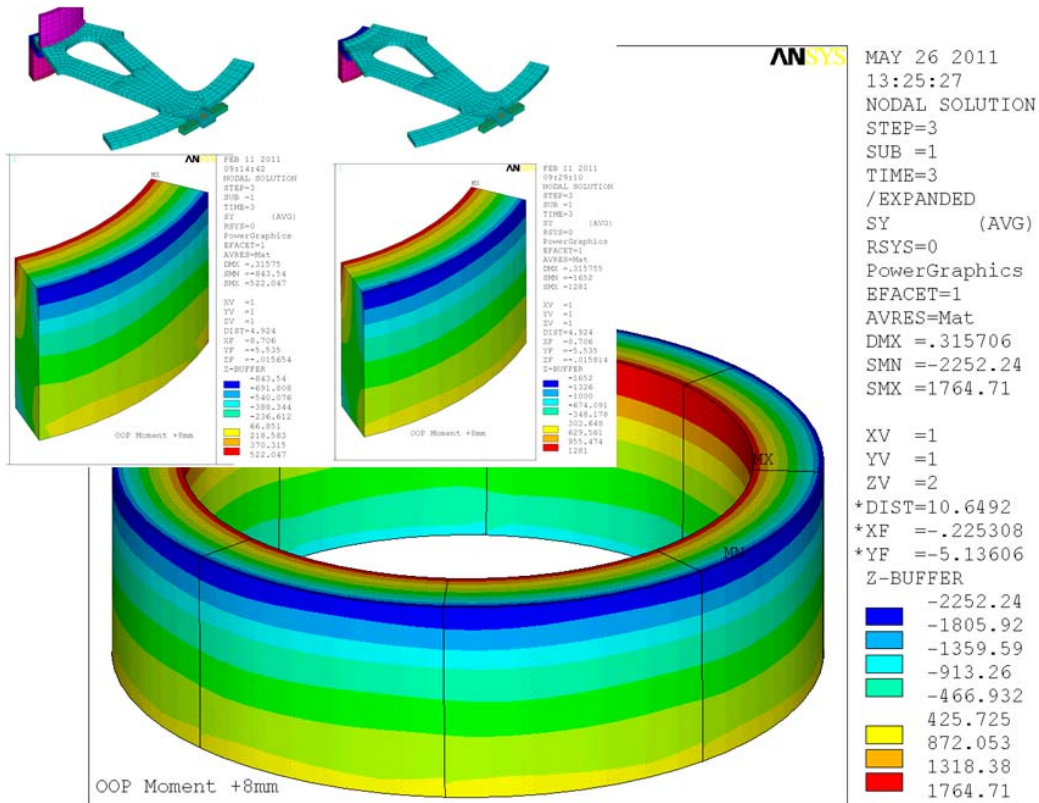

Figure 5.1-4 Spoked Lid with Bolted Outer Flange G-10 Collar Vertical Stress

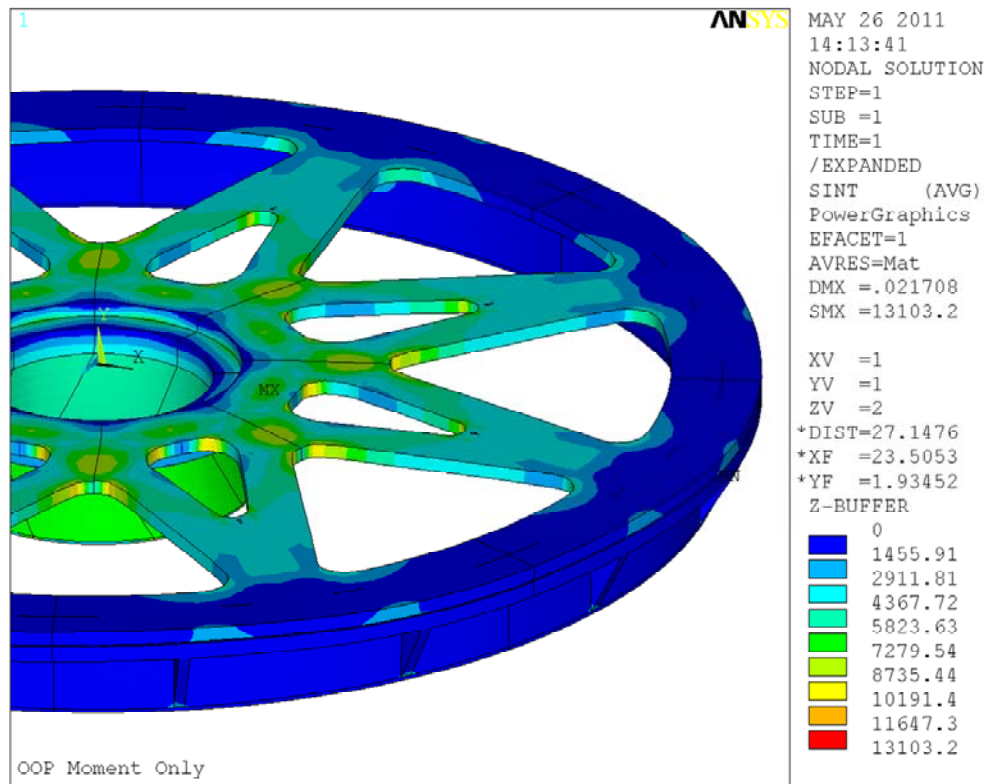

Figure 5.1-5 Spoked Lid with Bolted Outer Flange, Stress with OOP Torque Only

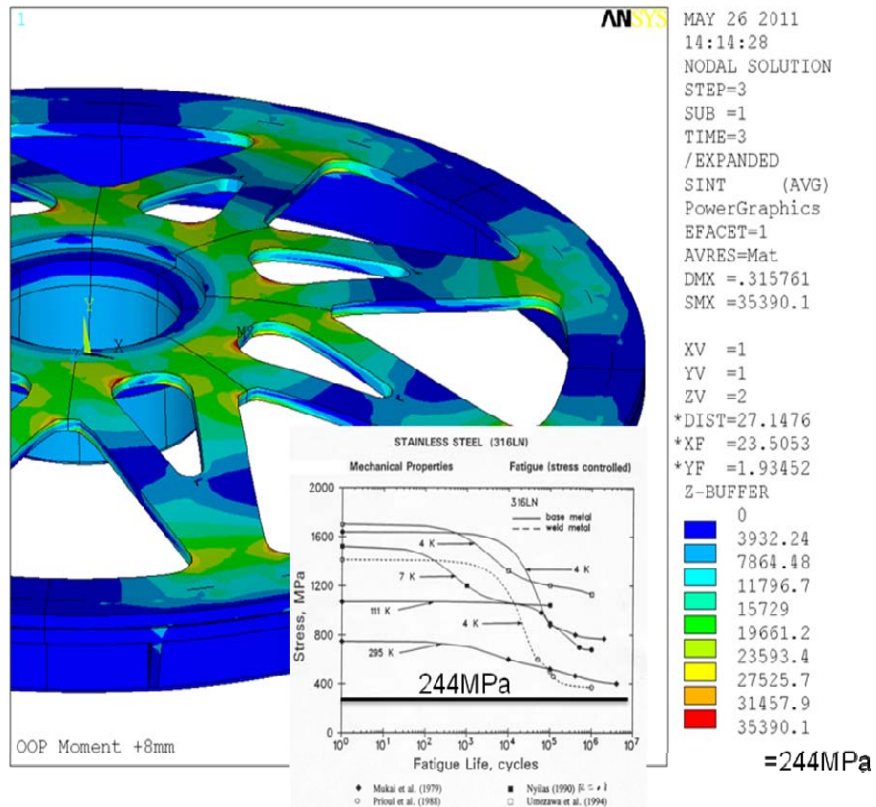

Figure 5.1-5 Spoked Lid with Bolted Outer Flange, Stress with OOP Torque Only

5.2 Frictional Effects of Sliding Umbrella Restraint blocks

A concept that employed restraint lugs at the umbrella outer rim was investigated. This concept was intended to allow vertical motion via slippage at the lugs. Bolted cleats that appear in the aluminum block CAD models, were added at the lugs. The cleat bolts are 1/2 inch bolts spaced two inches apart. The 9000 lb design load *36 teeth/8 cyclic symmetry sectors, was added at the inner hub. The lid spoke design stresses out -. The cleat bolts are OK at 45 ksi if high strength.

If the lugs at the outer perimeter are frictionally restrained, one potential issue is the stick-slip at the cleat-lug detail. With a friction coefficient of .1 the OOP torque load is sufficient to stick the lug/cleat. As the TF heats and expands, the lug/cleat remains stuck bending the spokes and putting a moment on the inner TF collar. At 50% OOP load the cleat/lug remains stuck. At 25% of the load, it slips and springs upward the 8mm (or more dynamically) that the TF has expanded. This study led to the conclusion that the outer lugs need to be pinned or bolted.

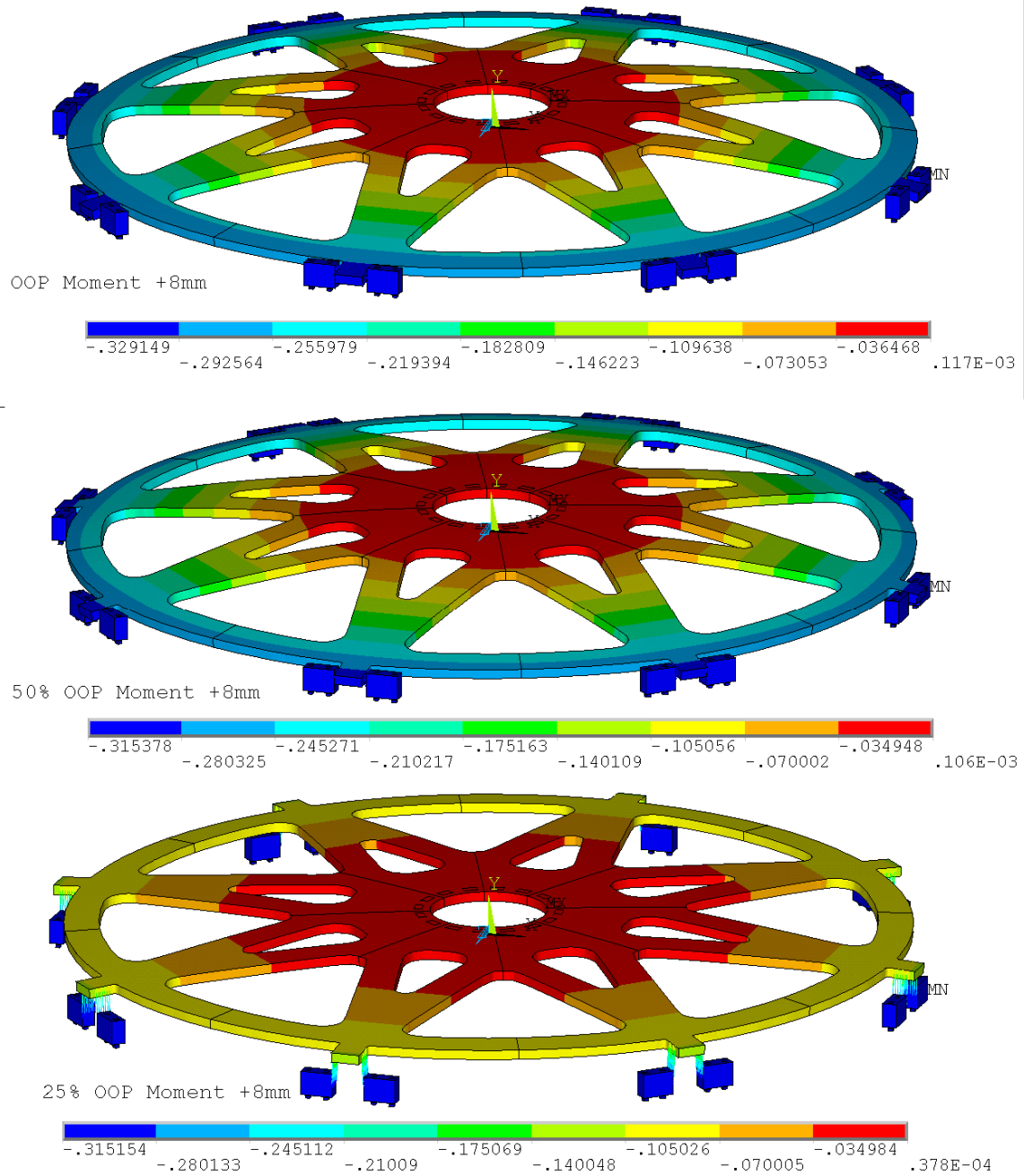

Figure 5.2-1 When the OOP force reaches 25% of nominal, the spoke lid springs upward

5.3 Upper Spoked Lid Pinned Umbrella Restraint Blocks

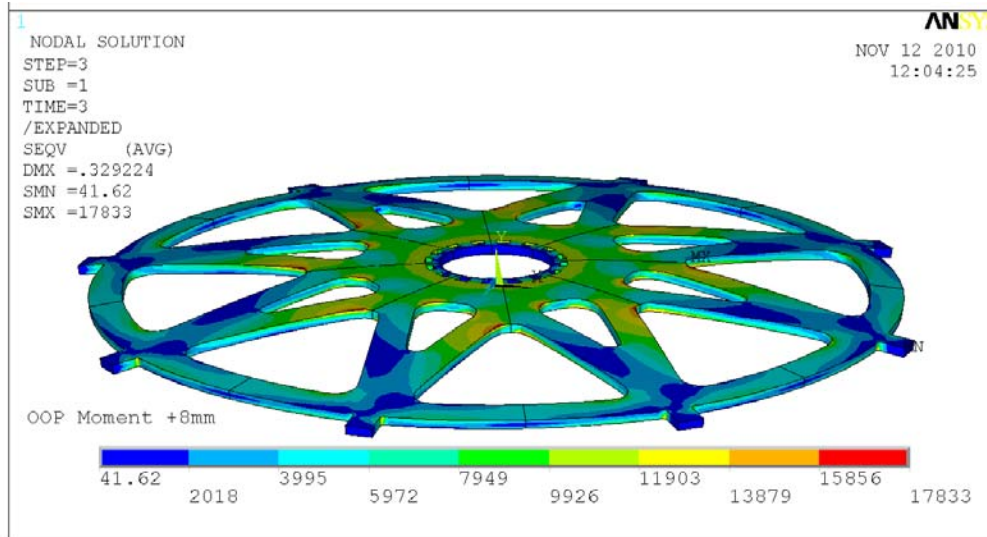

Figure 5.3-1 Pinned Lug Concept, Stress with OOP Moment, and Centerstack Growth

A concept that pinned the restraint lugs at the umbrella outer rim was investigated. This allowed vertical motion of the centerstack without imposing a prying moment on the outer connection hardware. It also minimizes the prying moment at the ID. The local pin hardware was not modeled. The "hinge" behavior was modeled by connecting a single node at each side of the lug - to the umbrella structure rim.

5.4 Upper Spoked Lid Bolted - Fixed Umbrella Restraint Blocks

In this concept only the lugs were bolted to the umbrella rim. This concentrated all the moment and rotations at the lug and overstressed it. Spreading the moments around the full perimeter of the umbrella structure rim, discussed in section 5.1, eased the stresses where the lug detail had been but imposed more flexure in the spokes, which translated to higher spoke stresses than in the pinned lug design.

5.5 Bending Moments at the ID TF Collar - Possible Mitigation

The inner radius of the upper spoked lid is attached to the G-10 Collar that is pinned to the TF flags. As the TF central column heats during a shot, it displaces 8 mm vertically, and the lid must flex -or translate upward to absorb this displacement. Pinned or frictional restraint at the outer diameter connection to the umbrella structure produces a bending moment on the spokes that is reacted at the inner hub of the lid/collar assembly. The bending moment or rotation must be accommodated by the G-10 collar. In this study, the collar is included in the model. The vertical stress distribution is computed at the top of the collar. This stress distribution is then matched in Ali Zolfaghari's TF flag analysis, reference [6]. As a part of modeling the collar, an additional hub was considered that would have reduced the moment. The stresses in the collar have been found acceptable without the added hub. [6]

The early estimate of the prying moment at the bolt circles was 6300 N-m per meter of perimeter. The prying moment can probably be reduced by reducing the assumed thickness of the 5/8 in thick lid. A flex plate or cover or "lid" is intended as the structure that extends from a connection to the TF central column flags to the outboard edge of the umbrella structure. These details are only concepts in the drawings currently, but a simple representation of the plate is included in the global model [1]

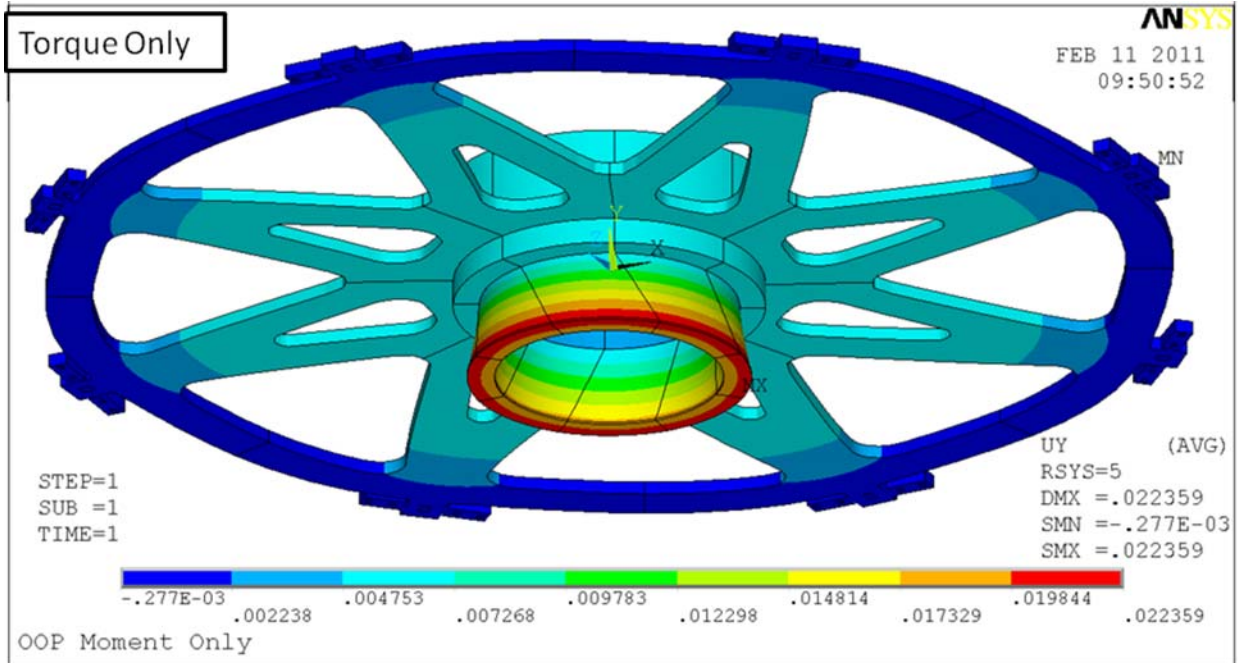

Figure 5.5-1 Hub Concept Torsional Displacements. The added is Above the G-10 Collar that is Twisting

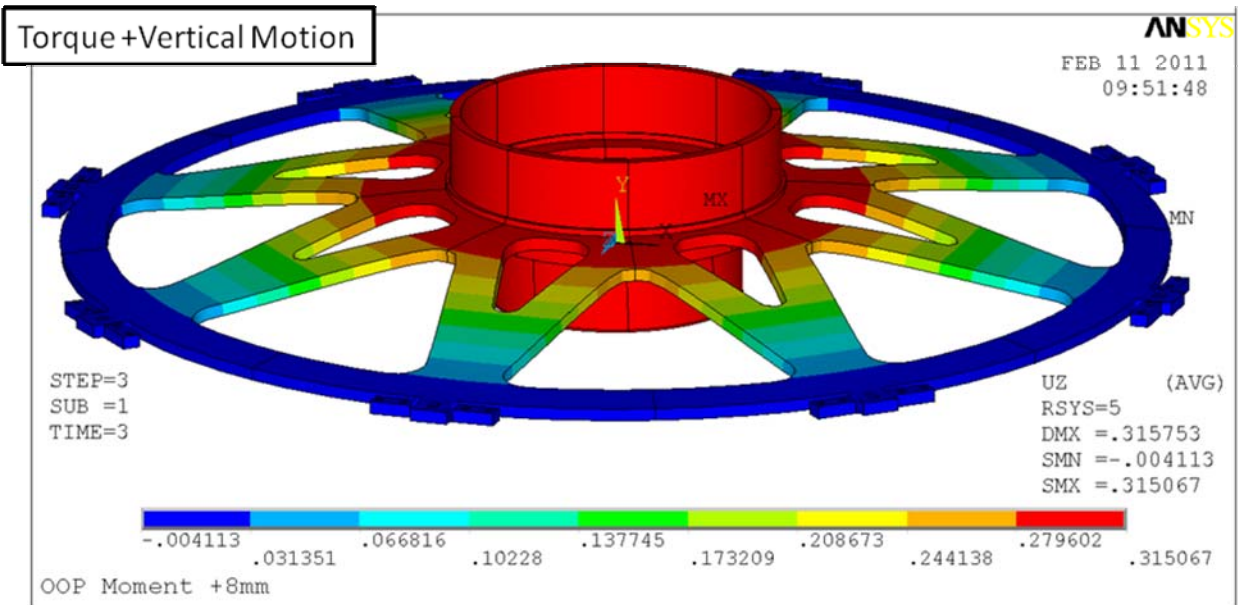

Figure 5.5-2 Hub Concept Vertical Displacements

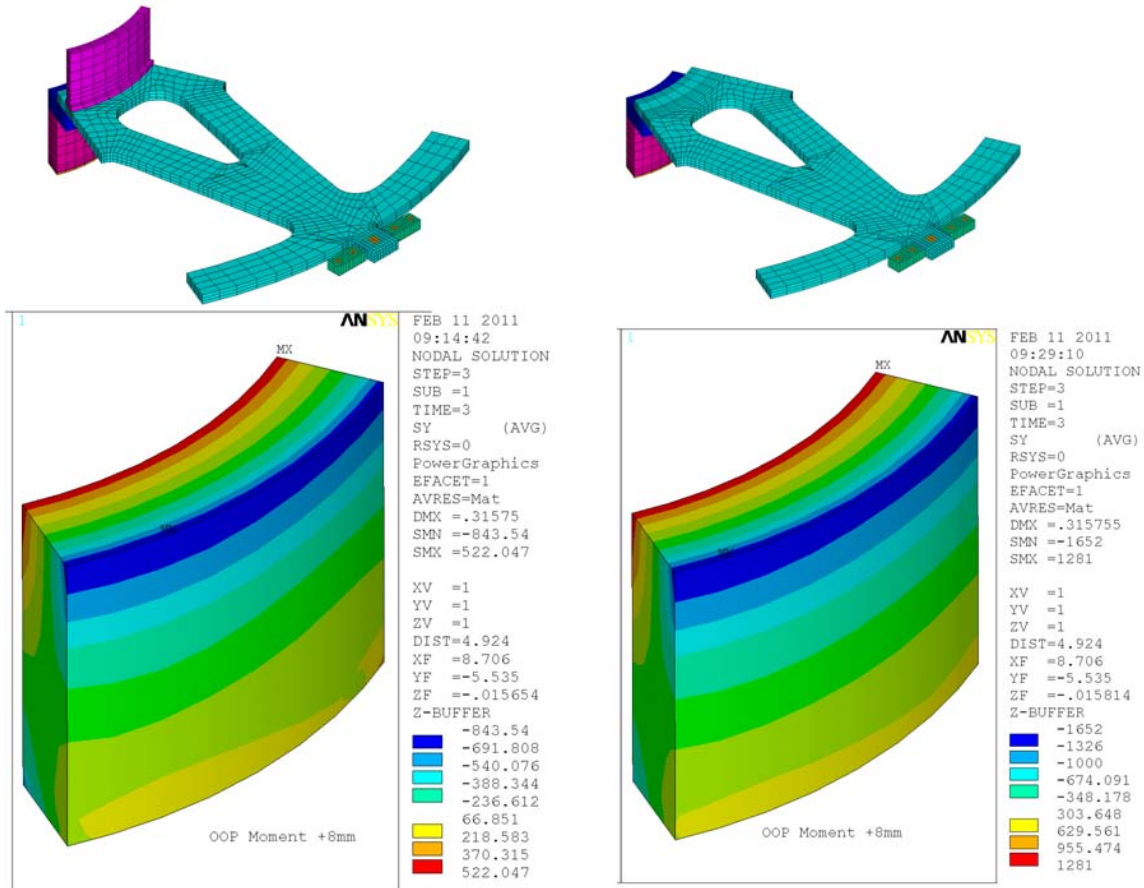
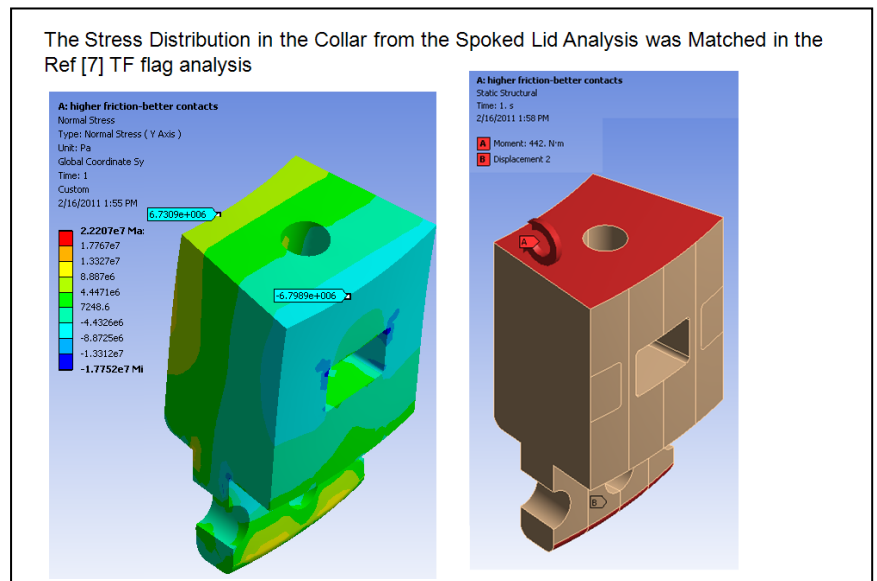

Figure 5.5-3 Vertical Stress distributions in the inner G-10 collar, with and without the hub

In figure 5.4-3, the connection to the inner crown was modeled with and without a metal hub extension. The vertical displacement of the TF central column was imposed. The resulting vertical stress distribution was matched in the collar analysis [6]. A distributed moment was applied in the WORKBENCH model which was then scaled to reproduce the vertical stress. The hub improved the prying stress in the G-10 collar, but Ali qualified the collar stresses with the higher prying moment, and the metal hub has been omitted from the current design.

Loads and Moments on the TF Inner Leg Flag Collar

The vertical stress distribution in the collar was passed to Ali Zolfaghari. He first applied a unit moment and then scaled the moment to match the vertical stress distribution. This was updated at the end of May consistent with the vertical stress distribution shown in Figure 5.1-4 for the bolted gusseted outer rim.



6.0 Lower Spoked Lid with Offset

The lower spoked lid serves a similar purpose as the upper spoked lid - bridging between the outer lower rim of the lower umbrella structure. It is part of a complex multiply redundant load path for the OOP torque. The TF flex strap needed more territory and the spokes needed to be bent to clear the straps. The first design employed the bend. The FDR design employs a flat - not bent geometry. The bend introduced a compliance. Analyzing and explaining this effect, and its impact on the total machine torque load paths is important in understanding the design evolution.

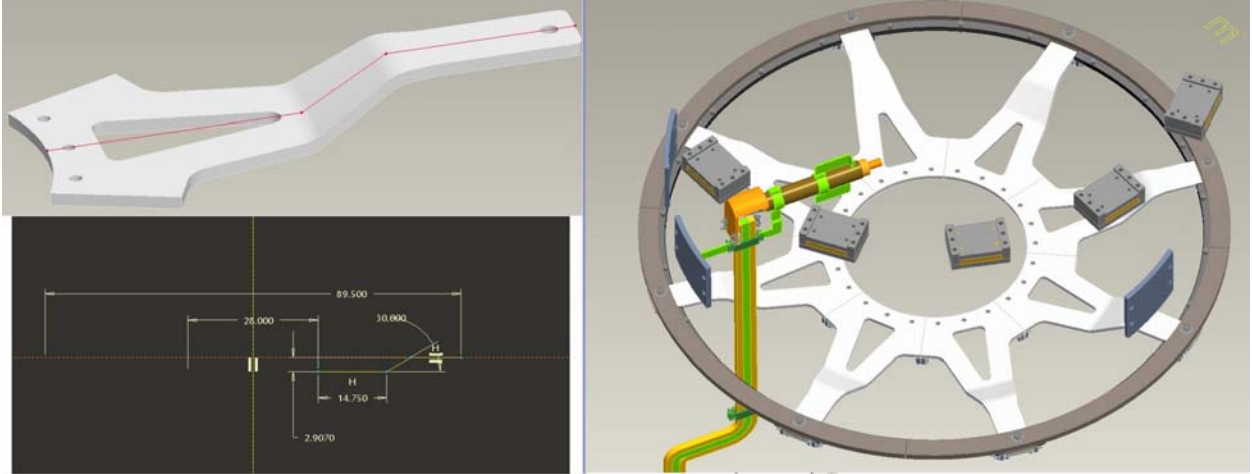

Figure 6.0-1 ProE plots of the lower spoked lid . Dimensions of the offset and View showing the routing of the OH coax lead - one of many connections passing through the lower lid.

The bend in the spokes in the lower lid will produce a different torsional stiffness than in the flat upper lid. To investigate this, the upper lid model was "upset" and the torque loads were applied

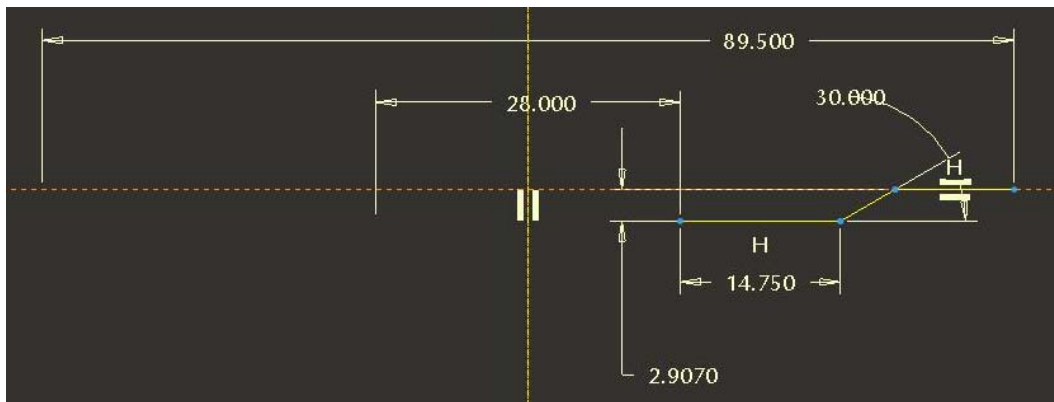

Figure 6.0-2 Dimensions of the offset of the spoke to accommodate the lower TF Straps.

The Lower Spoked Lid Model was Created by "upsetting" the Upper Model Mesh

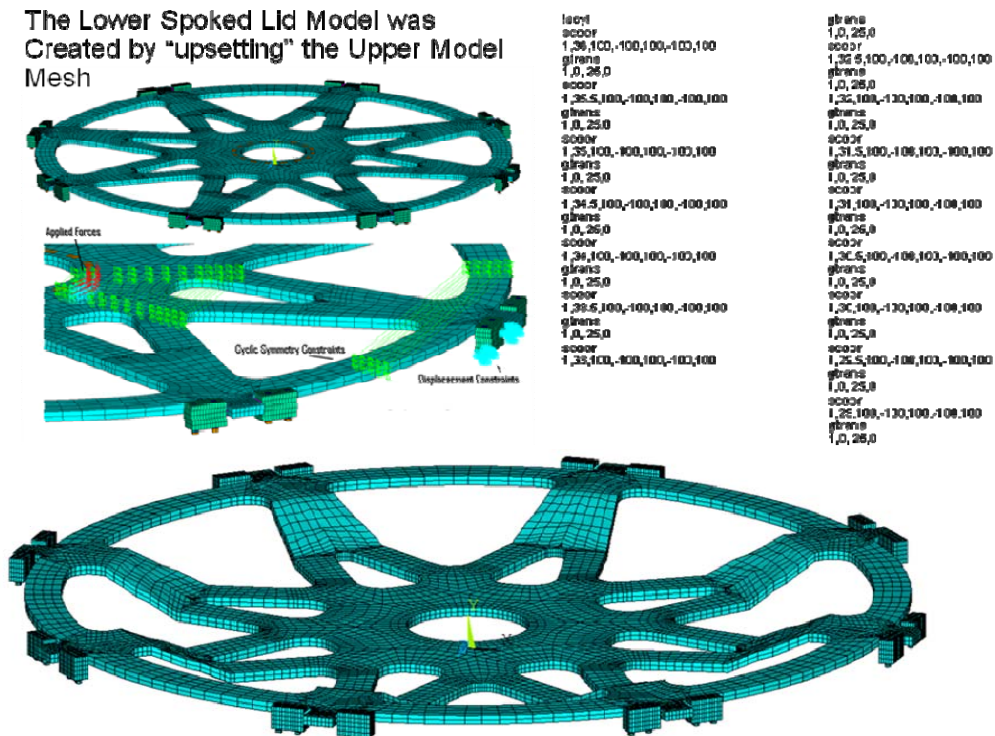

Figure 6.0-2 Symmetry Expansion of the Bent Spoke Model. and method of developing the lower spoke Model from the upper Spoked Lid Model.

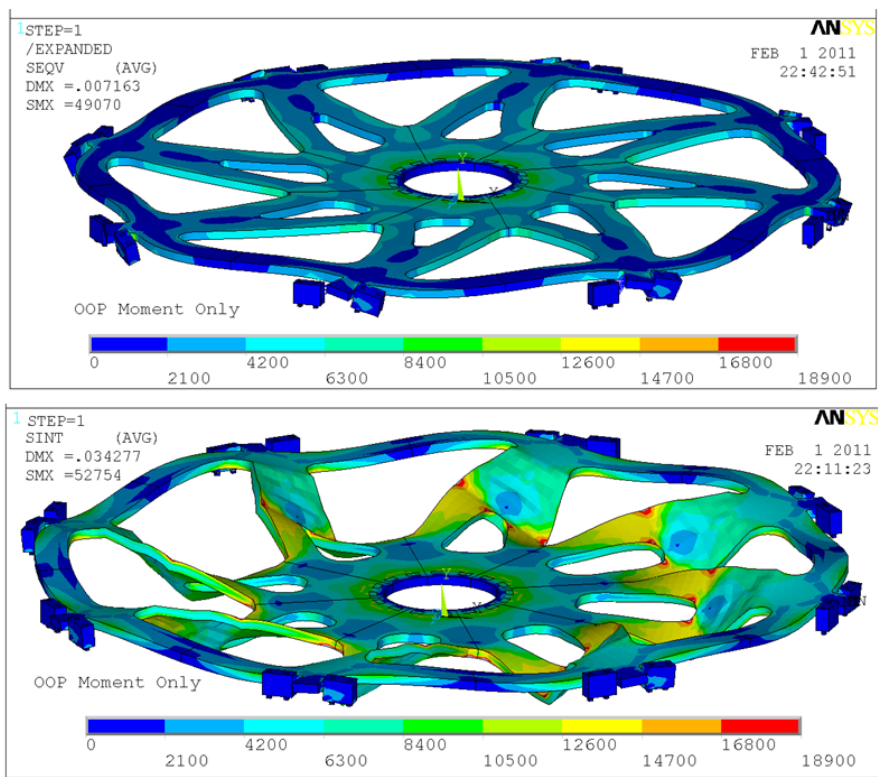

Figure 6.0-3 Results showing the Rotations of the legs Caused by the Bends

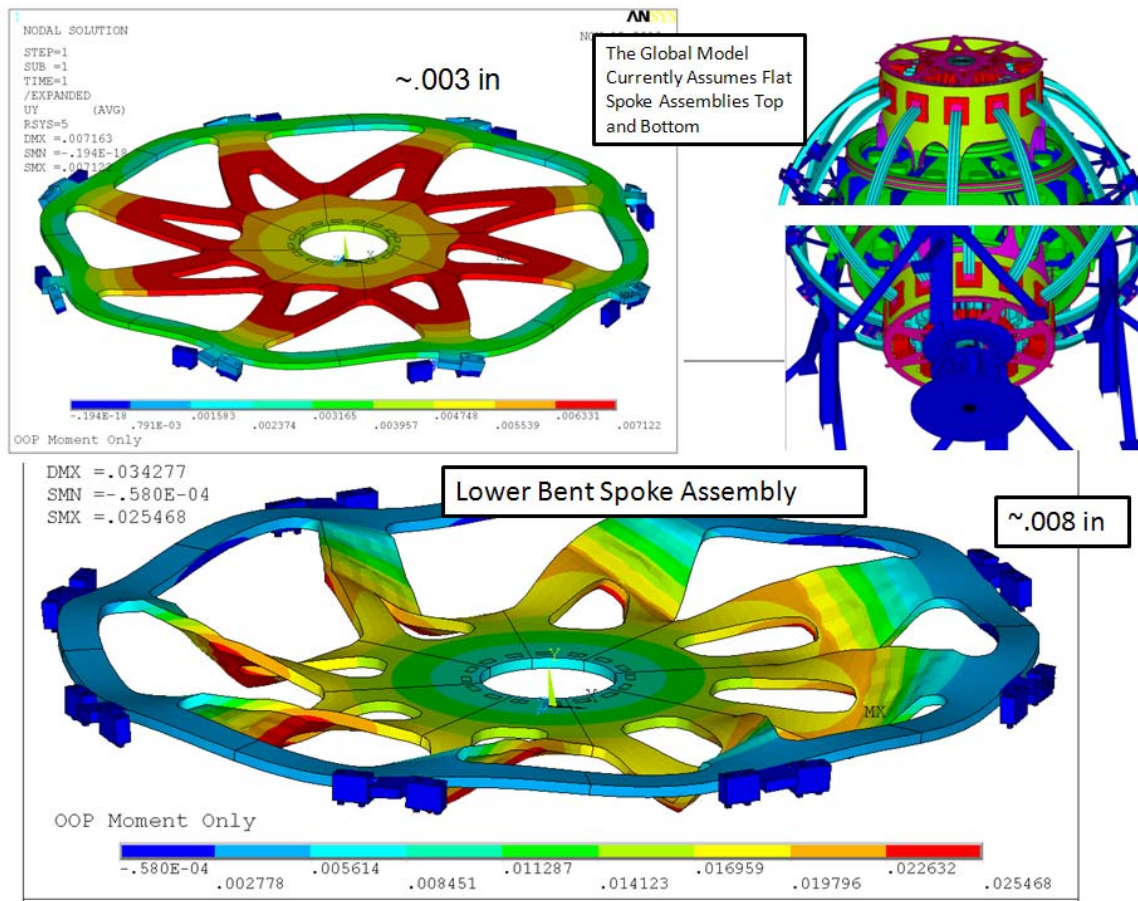

Figure 6.0-4 Results showing the Rotational Displacements for Flat and Bent Spokes.

The March 2011 IGES model of the lower spoked lid with the bend will be substantially less stiff than the upper. The spokes are narrower and the thickness is the same. - The torsional resistance goes as $b \cdot t^3$ so a modest increase in thickness should improve stiffness - but some of the "b" or spoke width has been lost in the process. Having the upper lid stiffer than the lower one will distribute more torsional shear stress to the upper end of the TF inner leg, which is already at the limit. It also shifts the torsional registration features of the lower structures to the bellows - which as a delicate part of the vacuum boundary, and could introduce operational reliability issue.

7.0 Global Model Results

The global model described in reference [1] was updated with the lower pedestal and spoked lid designs. This provides a means to qualify the stresses in the spoked lid. The pedestal included in the final design is a torsionally stiff design different than the pedestal used in the existing NSTX. In the global model response, the stiffness of the pedestal and the compliance of the lower spoked lid do not seem to be causing anything unacceptable. The inner leg torsional shear is altered, and this is discussed in section 7.2.

7.1 Stresses in the Spoked Lids

7.1.1 Normal Scenario Upper and Lower Spoked Lid Stress

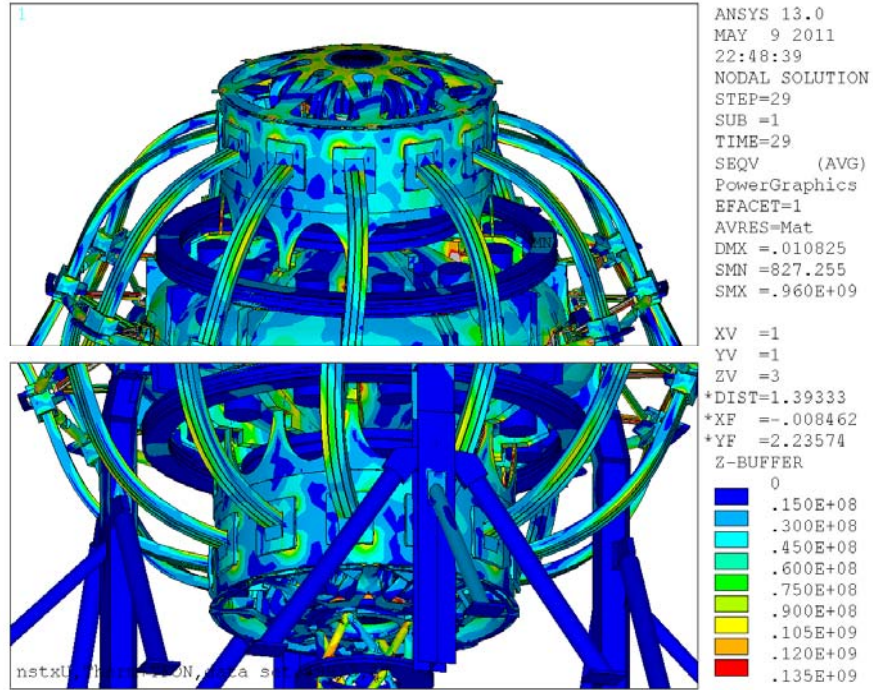

Figure 7.1.1-1 Global Model Results with Views of the Upper and Lower (Bent) Spoked Lid

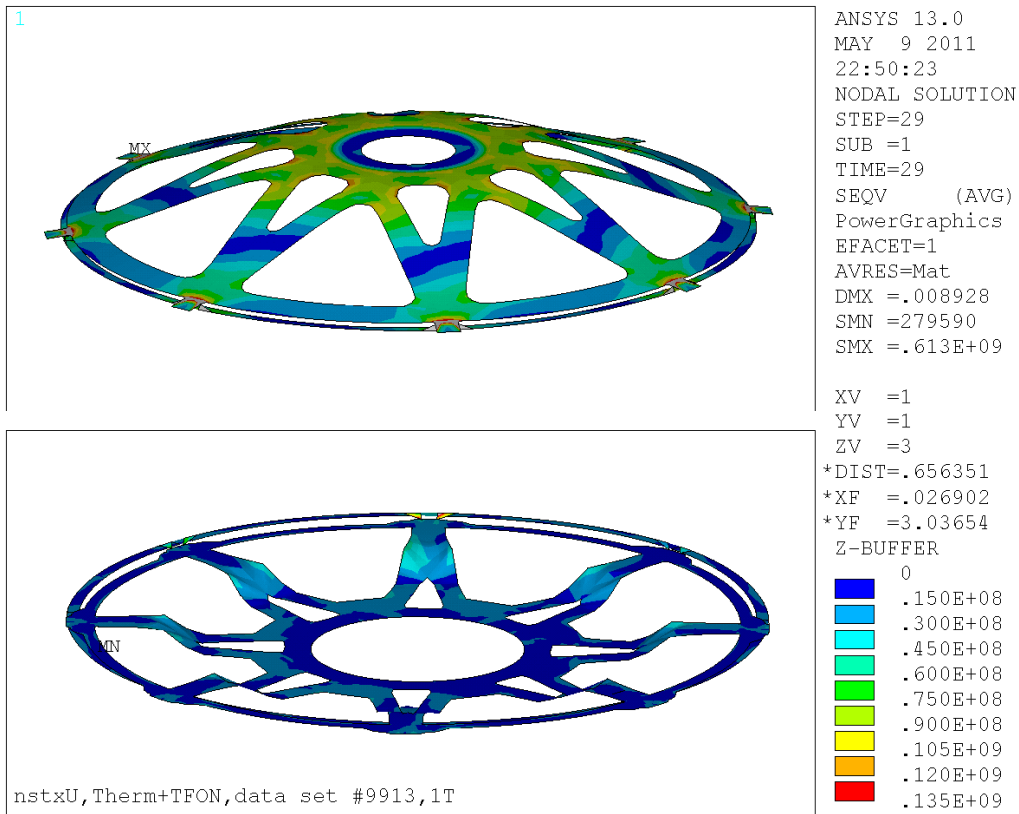
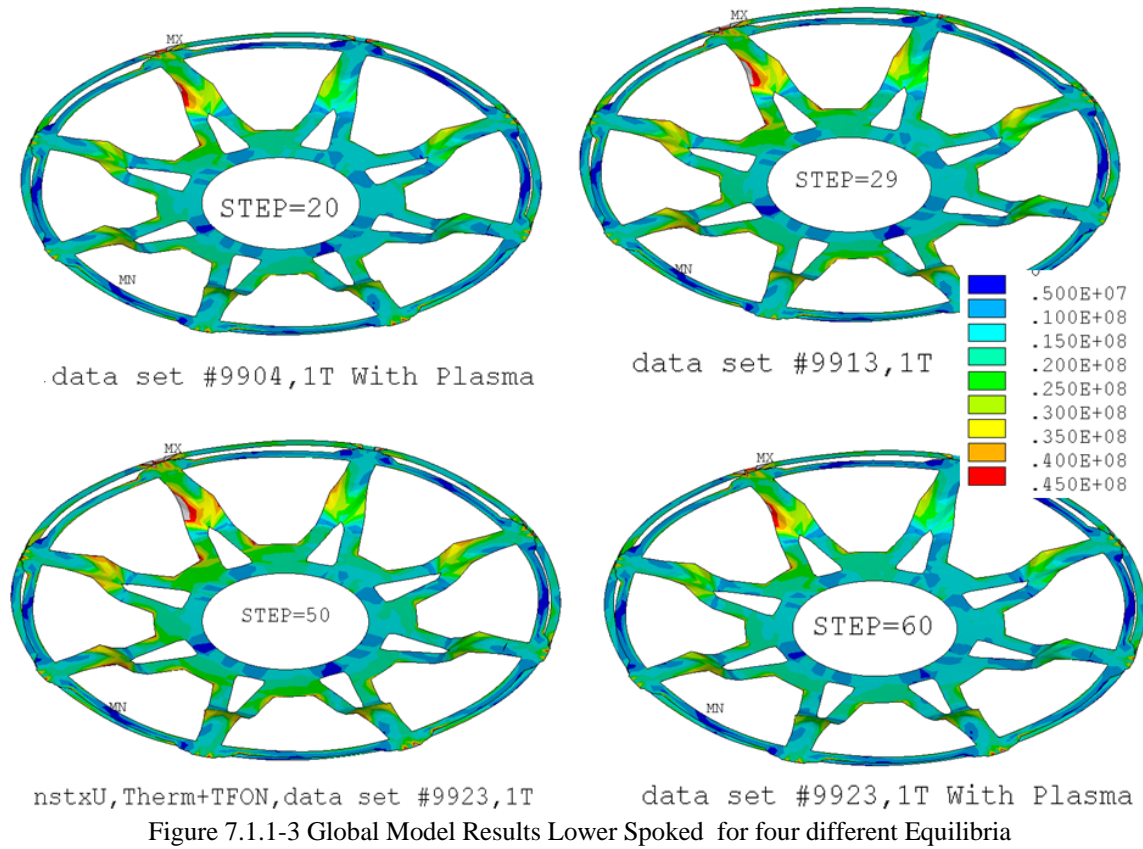

Figure 7.1.1-2 Global Model Results with the Upper and Lower Spoked Lids Selected



Note that there is very little difference between the results for various load files/equilibria

7.1.2 Bake Out Spoked Lid Stress

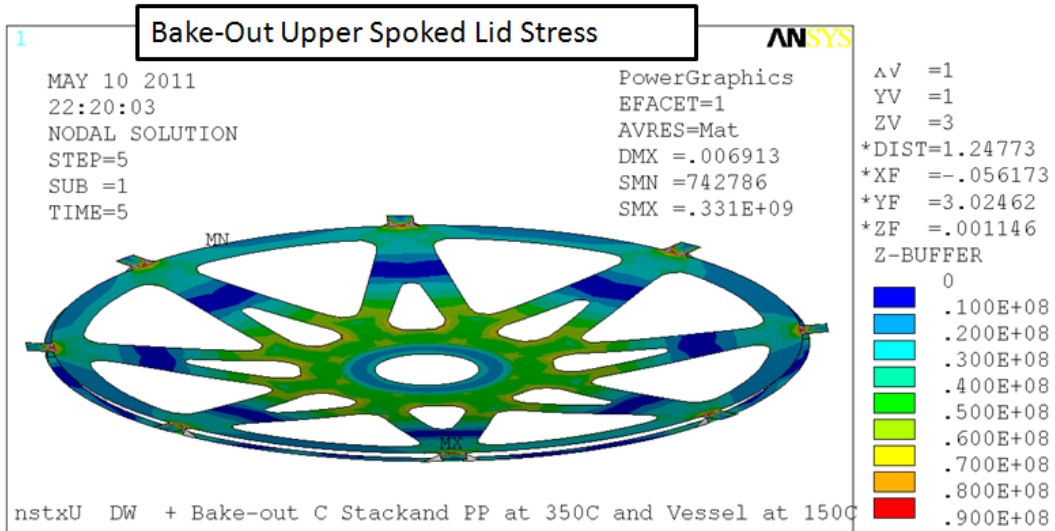

Figure 7.1.2-1 Global Model Bake Out Stresses in the Upper Spoked Lid

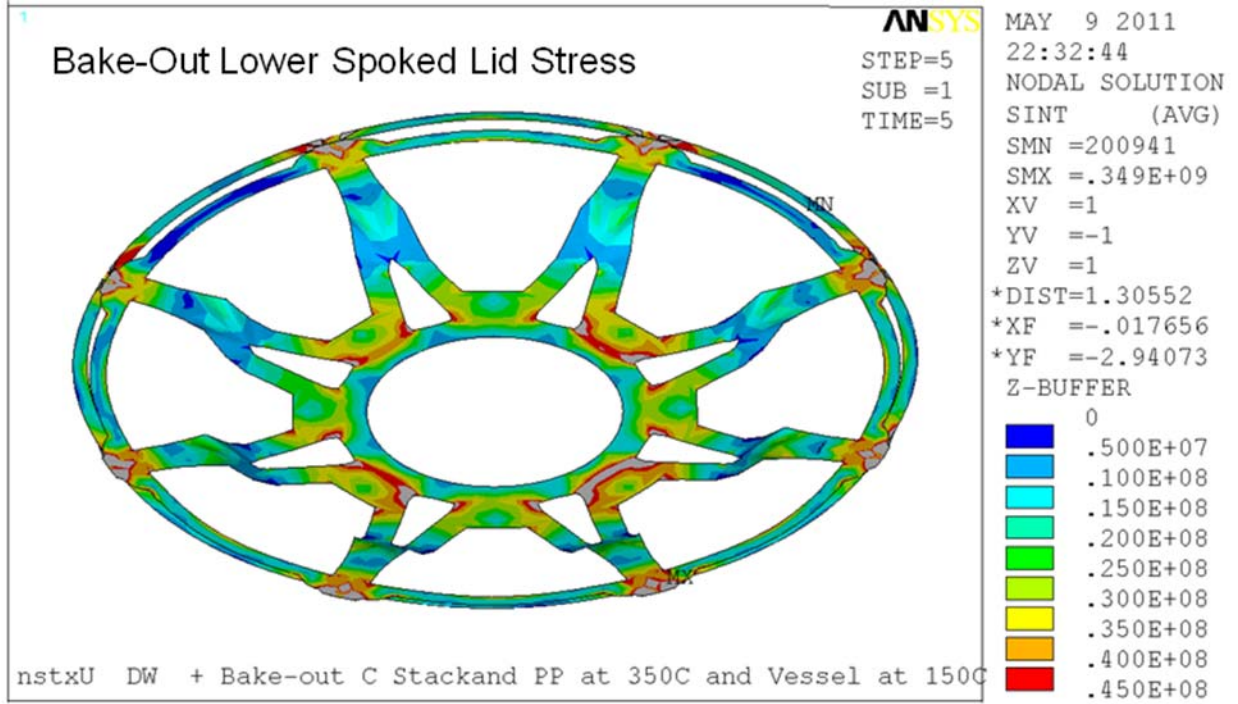

Figure 7.1.2-2 Global Model Results Lower Spoked Lids Bake-Out Stress

7.2 OOP Load Distribution with the FDR Spoked Lid Design

but the main purpose of including the lid in the global model is to address the need for torsional stiffness or compliance of the plate to ensure that the inner leg torsional shear stress is acceptable with the FDR configurations. The concern comes from the relative compliance of the bent spokes in the lower lid. Figure 4.0-2 shows the global model of the tokamak including the upper and lower spoked Lid

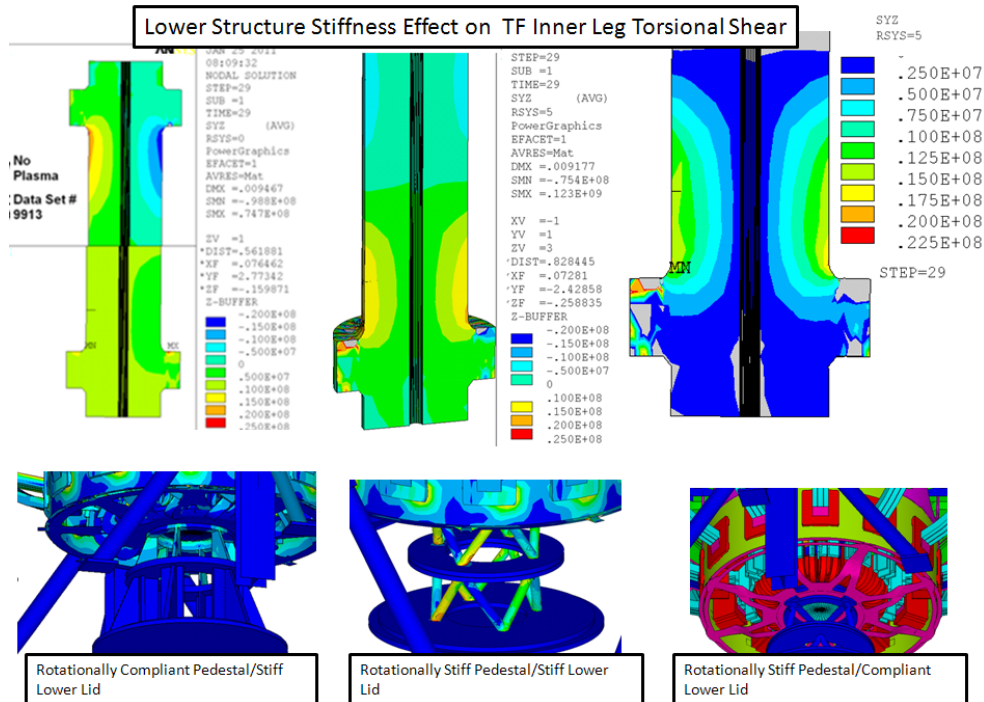

Figure 7.2-1 Comparison of TF Inner Leg Torsional Shear for Various Lower Assembly Stiffnesses

8.0 Halo Loads

Halo loads on the upper end of the centerstack casing are transferred to the bellows and then through the ceramic break to the vessel. The upper lid is not in this load path. Halo Currents load the passive plates and the centerstack casing. Casing loads are transmitted to the pedestal directly. The passive plate loads are transferred to the vessel and then to the foundation through the braced legs, and/or through the umbrella structure to the lower lid, then to the pedestal. Had the bent spokes of the lower lid been retained, they would have introduced a bending compliance to the lateral stiffness of lid. Most of the passive plate loading would have been transferred to the vessel braced columns, reacted internally within the vessel or resisted by inertia of the vessel and appurtenances. With the stiffer, flat lower lid, more of the halo loads will be reacted through the vessel structures and less through pedestal and vessel legs. Halo loads are not considered in the analysis of the spoked lids. Upper and Lower design loads for the centerstack casing halo loads was provided by Art Brooks [9]

Passive Plate 5/8 bolt Shear Stress Estimate for Halo Loads

- Estimate of 5/8 bolt shear load
-
- Each bracket has 12 bolts, each in double shear, shear area = .306in²
-
- 700000 amp halo current*.8m poloidally across the face of the PP
*1Tesla toroidal field*1.5 peaking factor /12brackets /12bolts per bracket / 2 shear planes per bolt = shear load per shear area = 2916N = 655 lbs or 2142 psi shear or 4.2 ksi Tresca

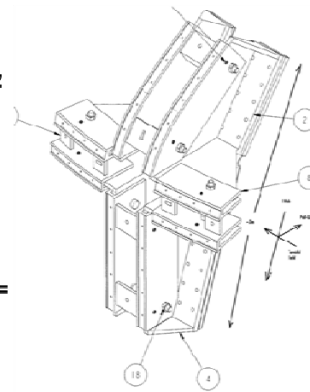

Figure 8.0-1 Figure from reference [8] calculating the Halo Current Loading on the Passive Plates

Inductive disruption loads on the vessel and passive plates are basically axisymmetric. Halo current loads can develop lateral loads in both the centerstack casing and in the vessel that will appear in connections between the outer vessel structure and the inner casing. These connections consist of the supports down to the floor - the pedestal and vessel legs, the spoked lid and the bellows/Ceramic break. Ideally the bellows and ceramic break should see little of this load.

For the halo currents a toroidal peaking factor of 2:1 shall be assumed in all cases. Thus the toroidal dependence of the halo current is $[1 + \cos(\phi - \phi_0)]$, for $\phi = 0$ to 360° where ϕ is the toroidal angle.

The net load is the integral of \cos^2 or .5 so the net load on the vessel and potentially by the spoked lid being transferred to the pedestal is $.5 * 700000 \text{ amps} * .8 \text{ m} * 1 \text{ T} * .2248 = 63000 \text{ lbs}$. At the lower lid with 8 spokes, this would be split over 8 outer one inch bolts or 7875 lbs per bolt. At the outer Umbrella structure rim, the lower spoked lid has been designed for $9000 * 36 / 8 * 13.5 / 40 = 13,700 \text{ lbs}$. Concurrence of a worst torque and a worst halo disruption should be considered a faulted case. The 1 inch bolts at the end of the spokes (In the flat Lower Spoked Lid Design) have a yield of 80 ksi and would have a yield shear capacity of $80 * \pi / 4 / 2 = 31000 \text{ lbs}$.

Appendix A Original Flex Plate

A flex plate or cover or “lid” is intended as the structure that extends from a connection to the TF central column flags to the outboard edge of the umbrella structure. These details are only concepts in the drawings currently, but a simple representation of the plate is included in the global model (Figure 1). The flex plate must allow the relative motions of the central column which is fixed vertically at the lower end by connections to the pedestal and to the lower TF flag extensions. The upper connections between the outer rim of the umbrella structure and the TF flags must allow the full vertical expansion of the central column. This is 9 mm at the elevation of the connection. The lid/flex plate is intended to bend and absorb the vertical motions elastically. Bending stresses develop at the ID and OD of the plate which produce prying moments at the bolt circles.

The prying moments or M_b inner and outer (in Figure 2) are the bending stress multiplied by the plate section modulus or on a per perimeter length basis, the moment is the stress times $t^2/6$

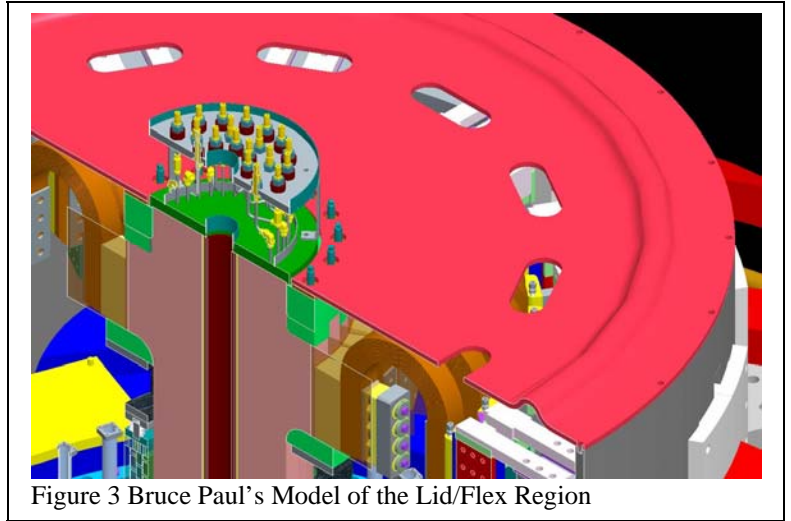

Figure 3 Bruce Paul's Model of the Lid/Flex Region

At the outboard bolt circle, the stress is about 150 MPa (Figures 4 and 5) and the moment is $150 \text{ MPa} \cdot (5/8/39.37)^{2/6} = 6300 \text{ N-m/m}$. If there were bolts every 20cm then the prying moment would be $6300 \cdot 2 = 12600 \text{ N-m}$ and if the distance from the bolt centerline to the edge of the plate were 10 cm, the bolt load would be 12600 N or 3000 lbs. In the global model, the inner edge is pinned, due to a plate element to solid transition. It will probably be a bolted connection, for design purposes, the inner flex can be considered as having 150 MPa bending as well as the outer diameter of the flex.

The original CDR concept employed a relatively thin (5/8 inch) disk or diaphragm

The prying moments or M_b inner and outer (in Figure 2) are the bending stress multiplied by the plate section modulus or on a per perimeter length basis, the moment is the stress times $t^2/6$

At the outboard bolt circle, the stress is about 150 MPa (Figures 4 and 5) and the moment is $150 \text{ MPa} \cdot (5/8/39.37)^{2/6} = 6300 \text{ N-m/m}$. If there were bolts every 20cm then the prying moment would be $6300 \cdot 2 = 12600 \text{ N-m}$ and if the distance from the bolt centerline to the edge of the plate were 10 cm, the bolt load would be 12600 N or 3000 lbs. In the global model, the inner edge is pinned, due to a plate element to solid transition. It will

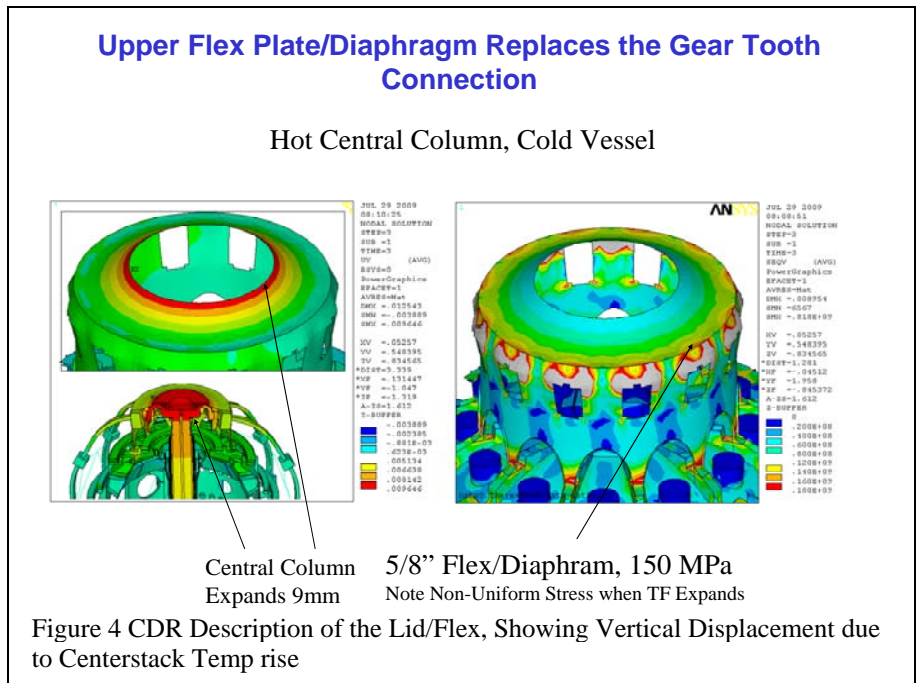

In the global model, the inner edge is pinned, due to a plate element to solid transition. It will

probably be a bolted connection, for design purposes, the inner flex can be considered as having 150 MPa bending as well as the outer diameter of the flex.

Lid/Flex/Diaphragm Stresses with Access Ports

The torsional load from the lid/flex/diaphragm is transmitted to the mechanisms that engage the torsional

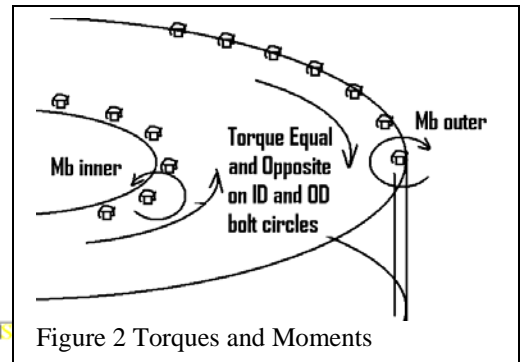
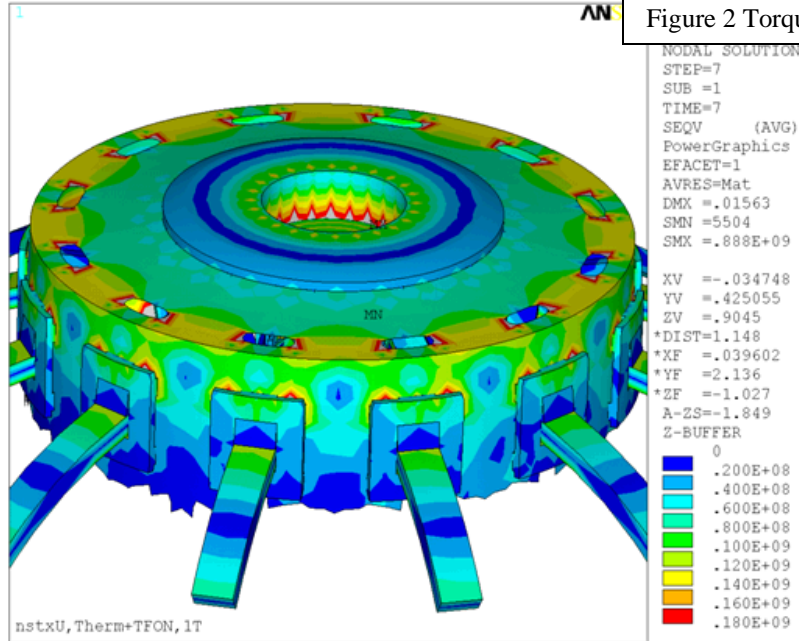
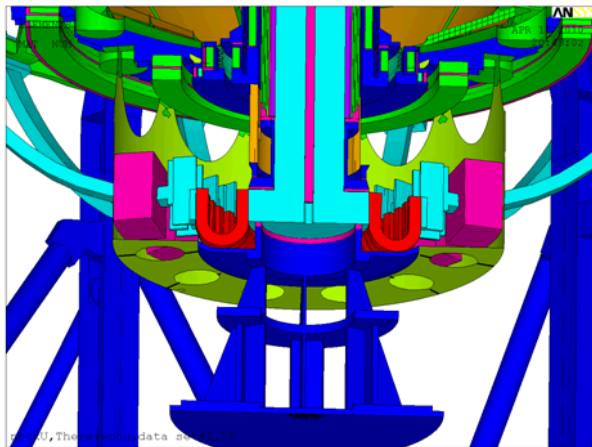

Figure 2 Torques and Moments



Upper Lid/Flex Plate With Access Holes Hot Central Column, Cold Vessel



Lower Segmented Plate with Circular Ports for Access

Appendix B Added Ring Section

The weakness of the bent spokes in the lower lid causes the torque to be shed to the pedestal, floor, and then to the vessel legs and vessel. If the lower spoked lid had to support the torque, the design would have to be stiffened substantially. In this Appendix, addition of a ring section was considered. It doubled the stiffness, and improved the stresses. The chosen design solution is to retain the torsionally compliant lid and rely on the torsional stiffness of the pedestal, floor, and vessel legs.

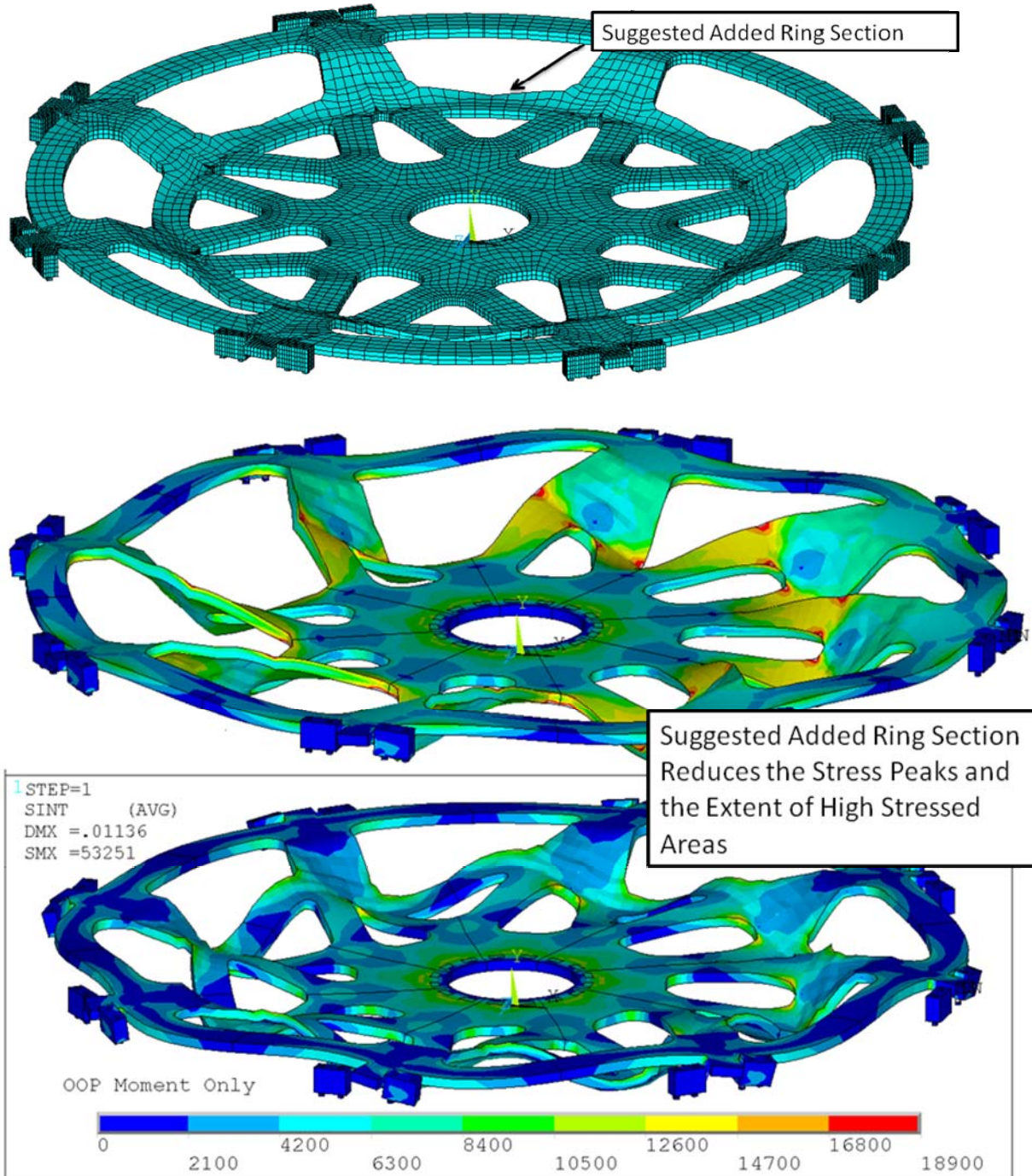

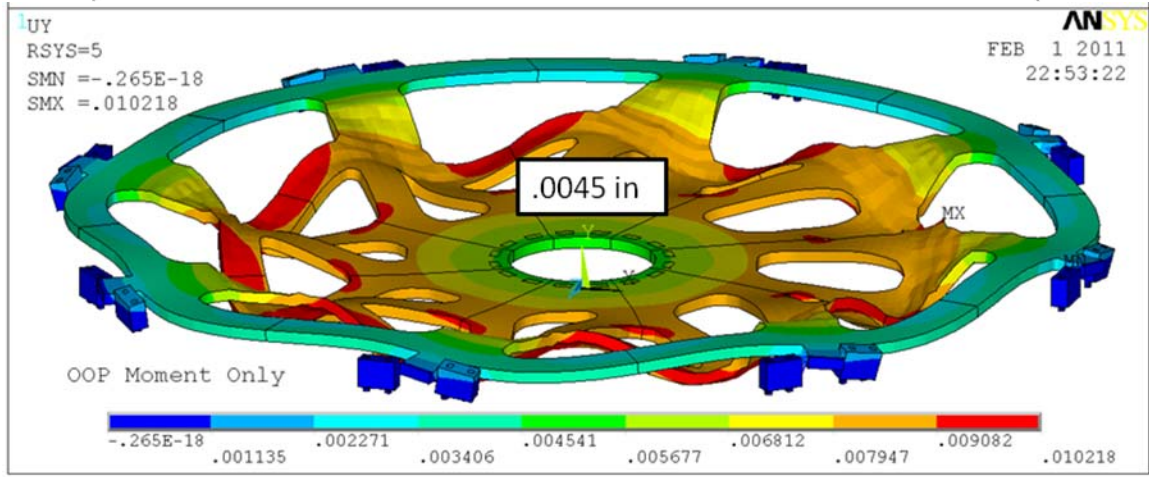
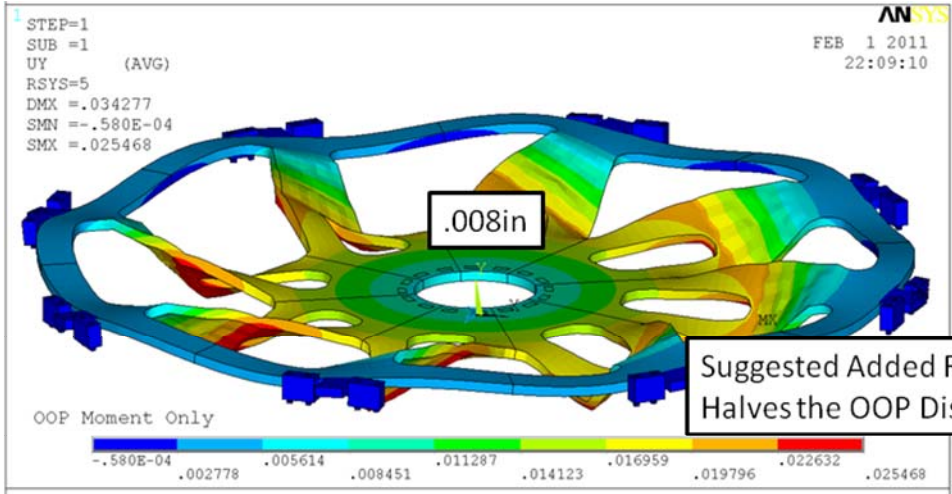

Appendix C

Information on the frictional Connection between Crown and Spoked Lid

Friction Effects

Ali assumed .35 as a friction coefficient. The criteria document requires that we assume mu nominal -.15 I think steel on G-10 is about .3 - so we will need a higher friction coefficient to qualify the joint. Phil Heitzenroeder has looked into this for NCSX . There are shim materials that we can place between the two surfaces to improve the friction coefficient. NCSX data is collected at:

http://ncsx.pppl.gov/NCSX_Engineering/Materials/index_Materials.htm

Another commercial site:

<http://www.esk.com/en/products-brands/products/frictional-connection-elements/friction-enhancing-metal-shims.html>

Criteria Document Content:

I-5.2.2 Coefficient of Friction

The allowable coefficient of friction (a) must always be determined in a conservative manner. Unlike stress, in some cases it is conservative to permit a coefficient of friction higher than the average measured value and, in some cases, lower than the measured value. The guidelines are

$$a_{min} = a - 0.15 \text{ but } \geq 0.02$$

$$a_{max} = a + 0.15$$

Friction values outside the range 0.1-0.4 require exceptional justification. The case of friction coefficient extremes must be considered as anticipated upset conditions in the design.

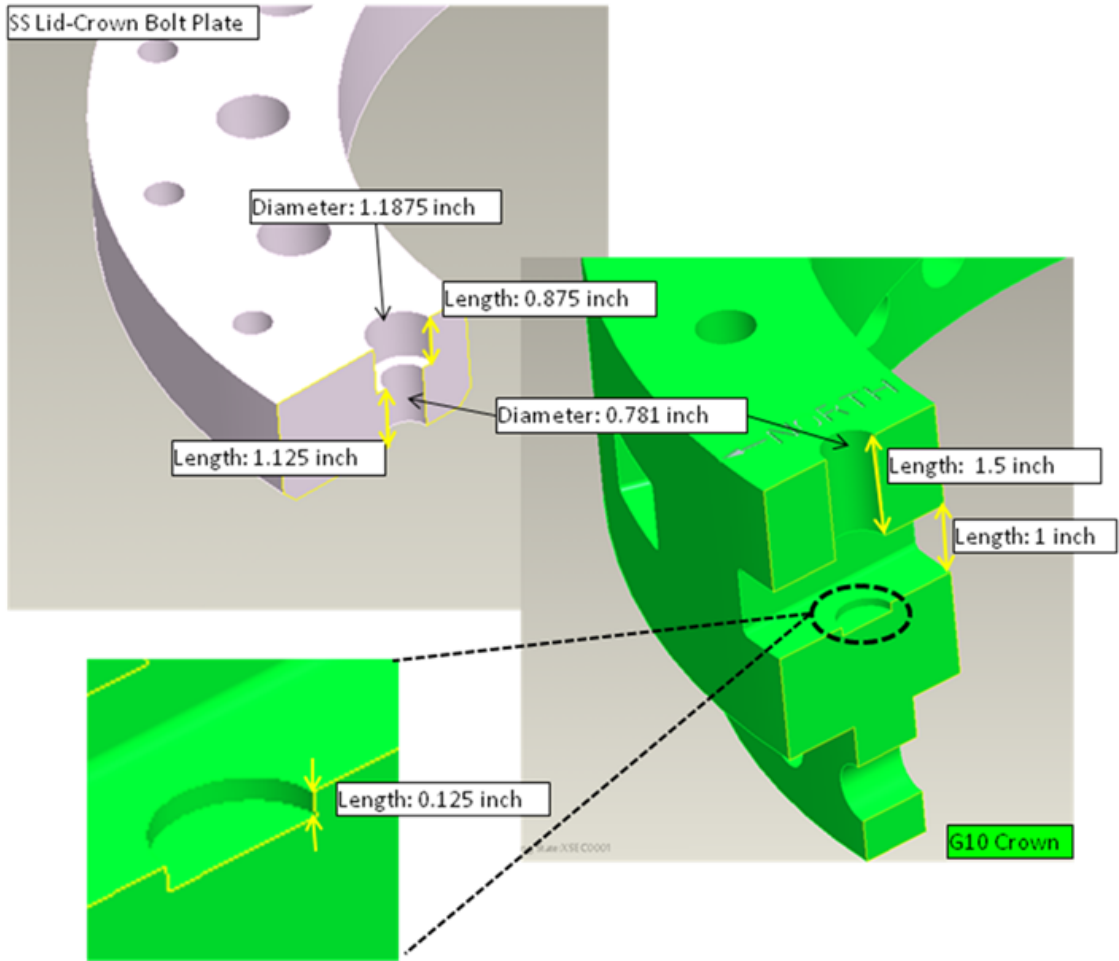

Thu 3/11/2010 8:21 AM

Peter,

Summing up the applied halo forces for the resistive distribution scenario (for the strike at $z=\pm 0.6\text{m}$) with PF and TF (1/R) fields I get:

Applied Load Sum on CS

Fx = -30695.6 N, Fy=Fz=0
Mx = 80400.7 N-m, My=Mz=0

I ran these thru a stress pass constraining all the points on the top and bottom flanges and looked at the reaction loads:

Reaction Loads on CS when Upper&Lower Flanges Fully Constrained

	Fx, N	Fy	Fz	Mx, N-m	My	Mz
Up	15347.	32464.	44662.	-40200.9	56846.7	-201.8
Low	15349.	-32463.	-44661.	-40199.6	-56848.9	201.8

The sum of the Up and Low values do add to negative the applied loads as expected. It just highlights the need to look at the reaction moments as well when considering support design loads.

Art