

NSTX

***Structural Analysis of the
PF1 Coils & Supports***

NSTX-CALC-133-01-00

August 28, 2009

Prepared By:

Leonard Myatt, Myatt Consulting, Inc,

Reviewed By:

Peter Titus, Branch Head, Engineering Analysis Division

Approved By:

Phil Heitzenroeder, Head, Mechanical Engineering

1.0 Executive Summary

A structural assessment of the NSTX CSU Inner PF coils (PF1a/1b/1c) is presented based on finite element simulations of the coils and their support structure. A parametric 2D ANSYS EM field model is developed and used to calculate Lorentz forces for each of the 96 equilibria (Menard version F). This also serves as a benchmark for the PPPL force calculation. Nine of these 96 cases produce the largest loads on the subject PF1 coils; faulted conditions are not addressed.

The 2D stress analyses indicates that an 80 kip launching force on PF1c requires a more robust hold-down design to stiffen the open coil case. A full cover is recommended over the four hold-down clips design. The 100 kip centering force on PF1a produces some bobbin flange deformations which would benefit from a slight increase in their thickness and/or stiffening gussets. Cu and insulation stresses are generally OK, but would gain some margin with any increases to the structure discussed above.

A 3D stress analysis is used to evaluate the non-axisymmetric structural elements of the support design. The model shows that the PF1a gussets which link the coil bobbin to the PF1b bobbin flange should be thickened and radiused. The net vertical loads which pass down through the three legs to ground produces some large bending stresses which must be addressed with a design/analysis cycle. The PF1c case needs a full cover with ID & OD bolt circles.

Differential thermal strains can lead to high bending stresses in the shell structure. However, a more detailed and consistent thermal-stress analysis is required.

2.0 Model & Analysis Approach

The EM field and stress analyses are based on the coil system and structure shown in Fig. 2.0-1. The structure is defined by a simplified version of L. Morris' CAD model, transmitted as lm_lmyatt_csu_section_thru.sat. Winding pack, conductors and insulation dimensions, along with a series of 96 equilibria currents are defined in C. Neumeyer's spreadsheet (NSTX_CS_Upgrade_090729.xls).

A 2D ANSYS EM model of the PF coil system is developed as shown in Fig. 2.0-2. Currents are applied to discrete conductors (PF1a/b/c) and smeared winding packs (OH, PF2-PF5). Forces are calculated for each equilibria current set and compared to the PPPL results.

The EM model is easily turned into a structural model, as shown in Fig. 2.0-3. Forces are imported for the most critical nine equilibria operating points. Stresses and deflection in the PF1 coils and structure are studied.

Although the coils are nominally axisymmetric, portions of the structure are not. A 60° sector of the Center Stack support structure is developed as shown in Fig. 2.0-4, along with a force application plot and loads from the nine critical equilibria operating points from Menard's ver. F equilibria: E1 loads on PF1c and E51 loads on PF1a.

In this 60° sector model, the PF1a&b structure carries the loads from E51: -441kN on PF1aU, +124 kN on PF1aL. PF1b carries zero current. The PF1c structure carries the loads from E1: +354 kN on PF1cU and -354 kN on PF1cL. Coincidentally, these PF1a&b loads put the max vertical force through the leg structure. These design-basis loading are applied to the 3D model, where the coil would push against the structure. Fault conditions are neglected for now.

Stress results are reviewed in section 3.0, along with some proposed design changes.

2.1 Analysis Notes: Units and Allowable Stress Levels

The EMag and stress analyses presented here are in SI units:

Flux Density [T]

Displacement [m]

Stress [Pa], 0.145 ksi/MPa

Force [N], 0.2248 lb/N, 1 kip =1000 lb

The Cu conductor used in the PF coils will have a hardness similar to that of the TF conductor

$S_y=262$ MPa, $S_m=(2/3)S_y=174$ MPa

Membrane + Bending Stress Limit at RT: $(1.5)174=262$ MPa

Membrane + Bending Stress Limit at 100C: $(0.9)(1.5)174=236$ MPa

The center stack coil support structure is made from Inconel 625:

$S_y \sim 65$ ksi, $S_{ut} \sim 130$ ksi, $S_m \sim 43$ ksi (300 MPa)

Membrane + Bending Stress Limit at RT: $(1.5)300=450$ MPa

The PF1 coils are insulated with Epoxy-Glass, which has a RT ultimate shear strength of 65 MPa (R. P. Reed, "Estimated and Compiled Properties of Glass/101K Epoxy/Kapton Composite Properties at Room Temperature," July 15, 2009).

– $S_s = (1/2 \sim \text{accounts for bond to Cu})(2/3 \text{ from Zatz' NSTX SDC})(65 \text{ MPa}) = 22 \text{ MPa}$

INCOLOY 625LCF Fatigue Curve

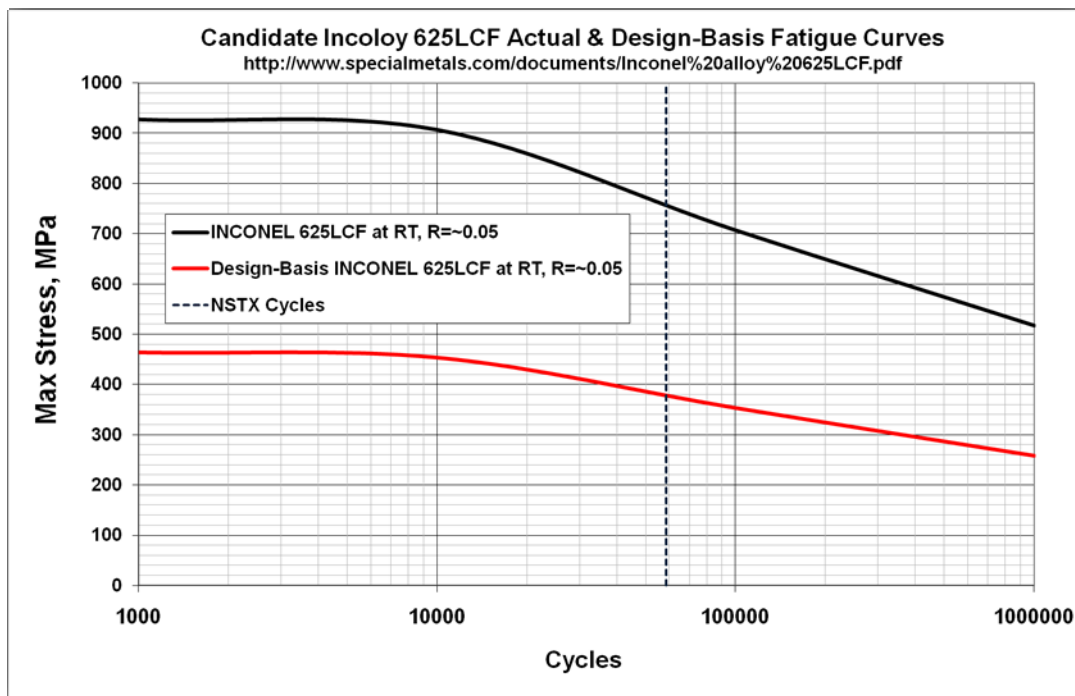

Fig. 2.0-1 Center Casting Drawing & Partial Solid Model (courtesy L. Morris)

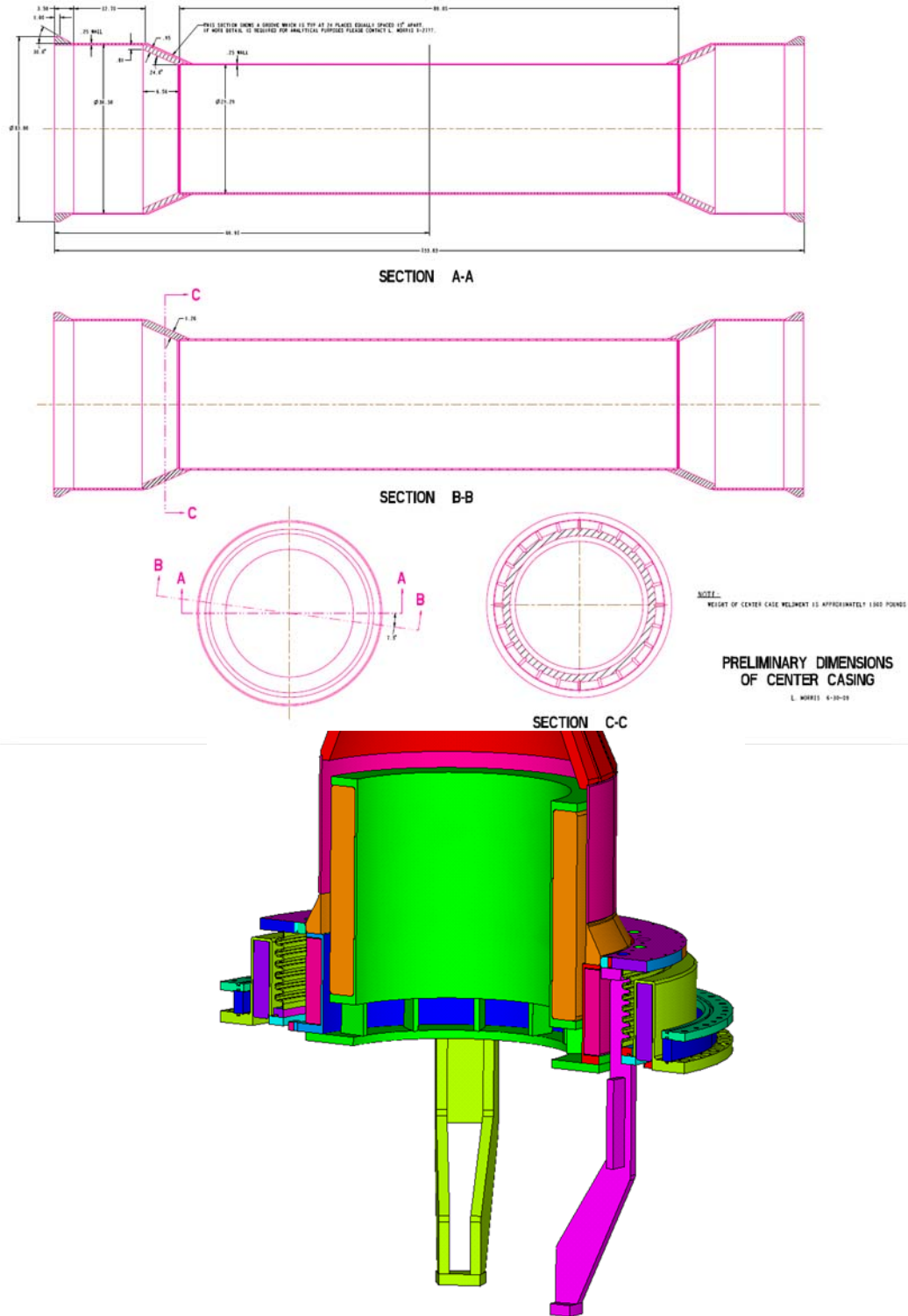

Fig. 2.0-2 2D ANSYS Magnetic Field Model and Typical Results

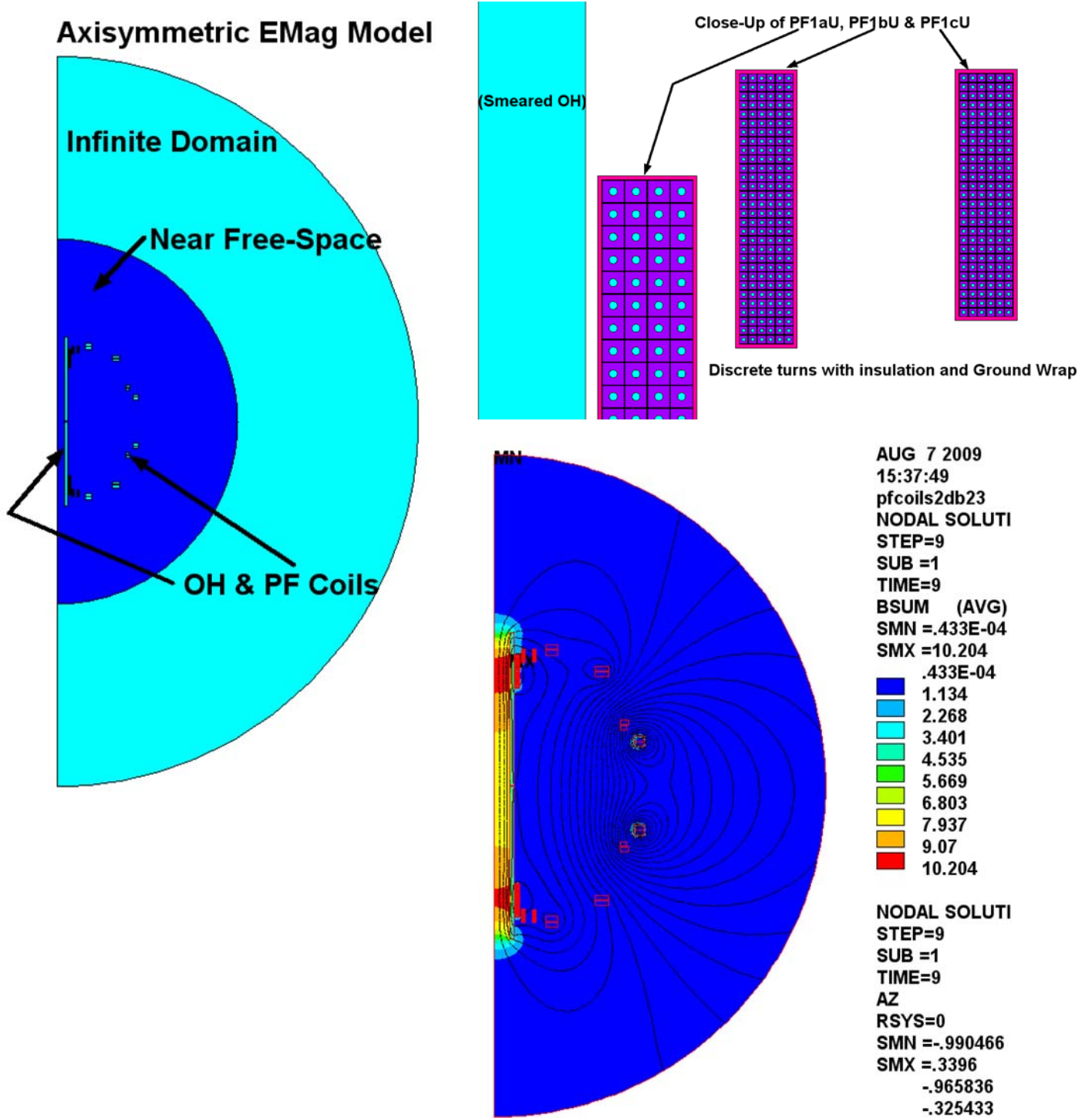

Fig. 2.0-3 2D Structural Model with Discretely Modeled PF1 Coils

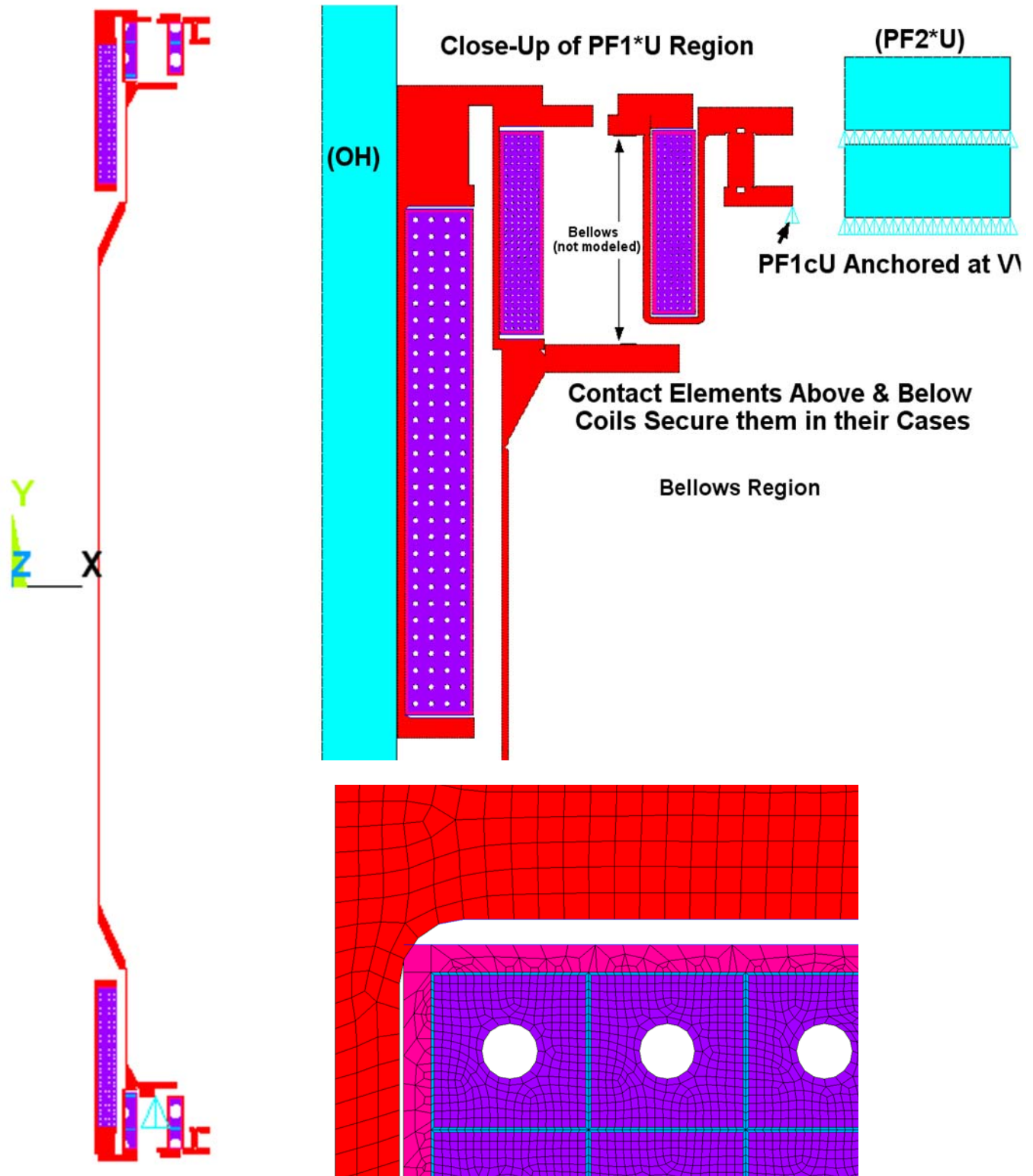
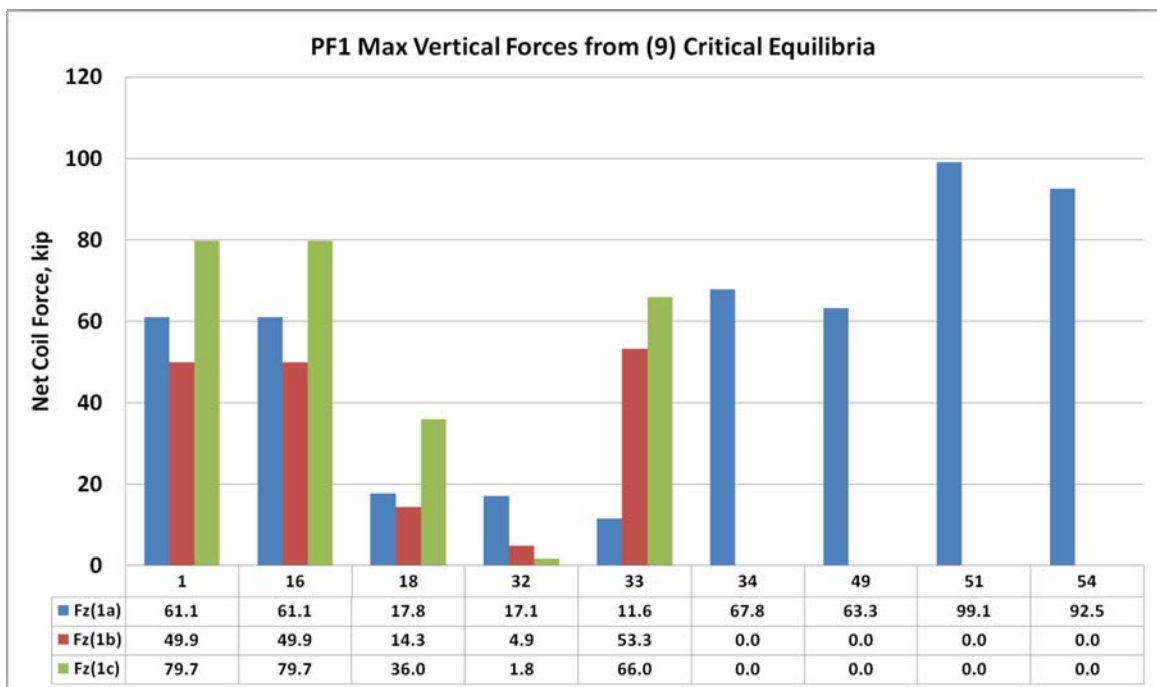
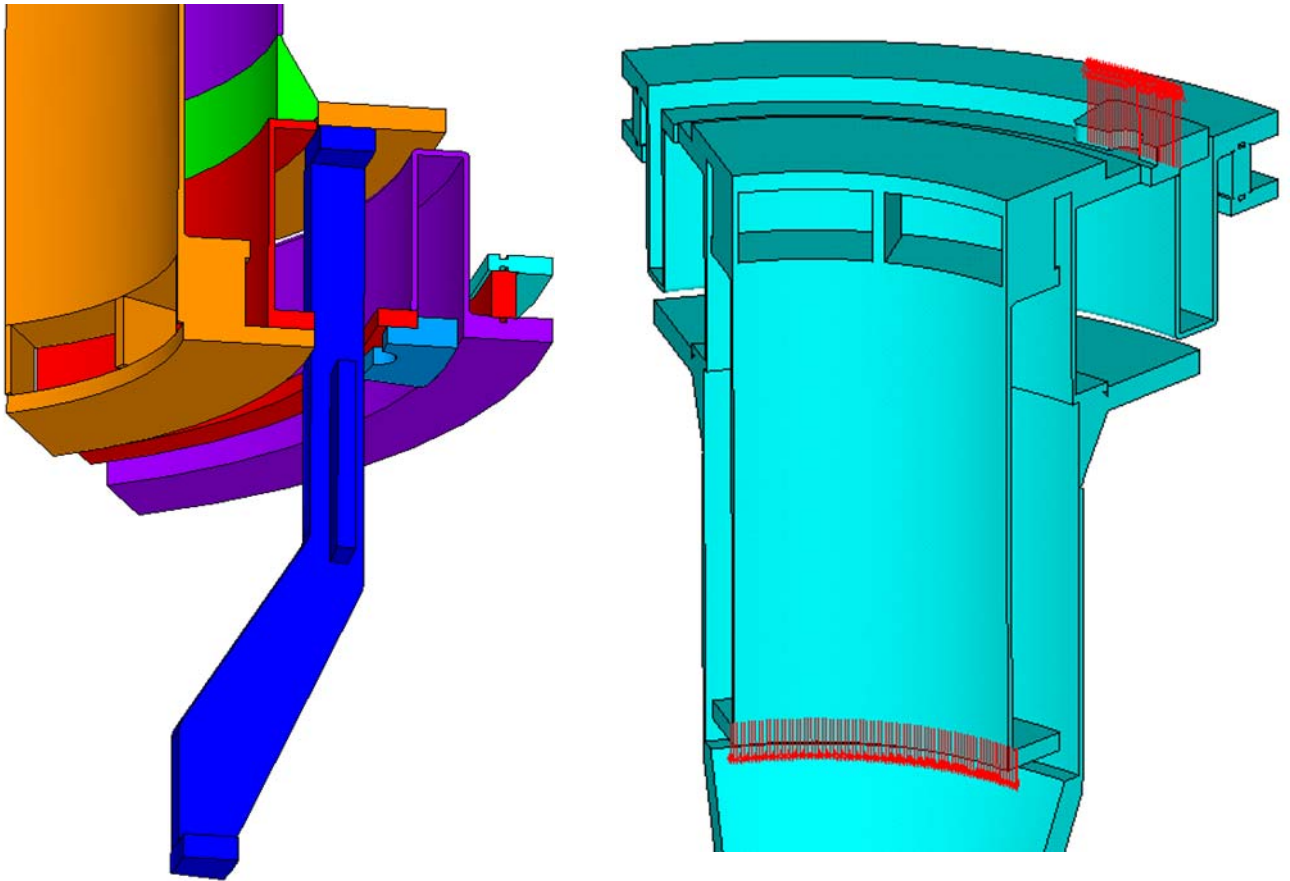

Fig. 2.0-4 3D Structural Model (Lower Region), Simplistic Load Application & Critical EM Load Chart



3.0 Results

3.1 2D Stress Results

With currents defined by E1, PF1aU is drawn towards the machine mid-plane while PF1cU is pushed away from the machine mid-plane. The PF1aU bobbin flange reacts the centering load from the coil and rolls down, resulting in a stress of 110 MPa (16 ksi). This is well below the 450 MPa limit, but the local contact will drive up the coils' insulation shear stress.

The upward load on PF1cU is reacted by (4) "dogs" which are bolted to the coil case ID flange. In 2D, these discrete dogs (brackets) appear as a continuous ring (non-conservative modeling). The open section has minimal rotational stiffness and experiences a bending stress of ~470 MPa (68 ksi). This is above the Inconel 625 and 304SS bending stress limits of 450 and ~300 MPa. The actual stress in the bolted brackets is also a concern.

Fig. 3.1-1 Stresses in the PF1aU bobbin and PF1cU case Structures

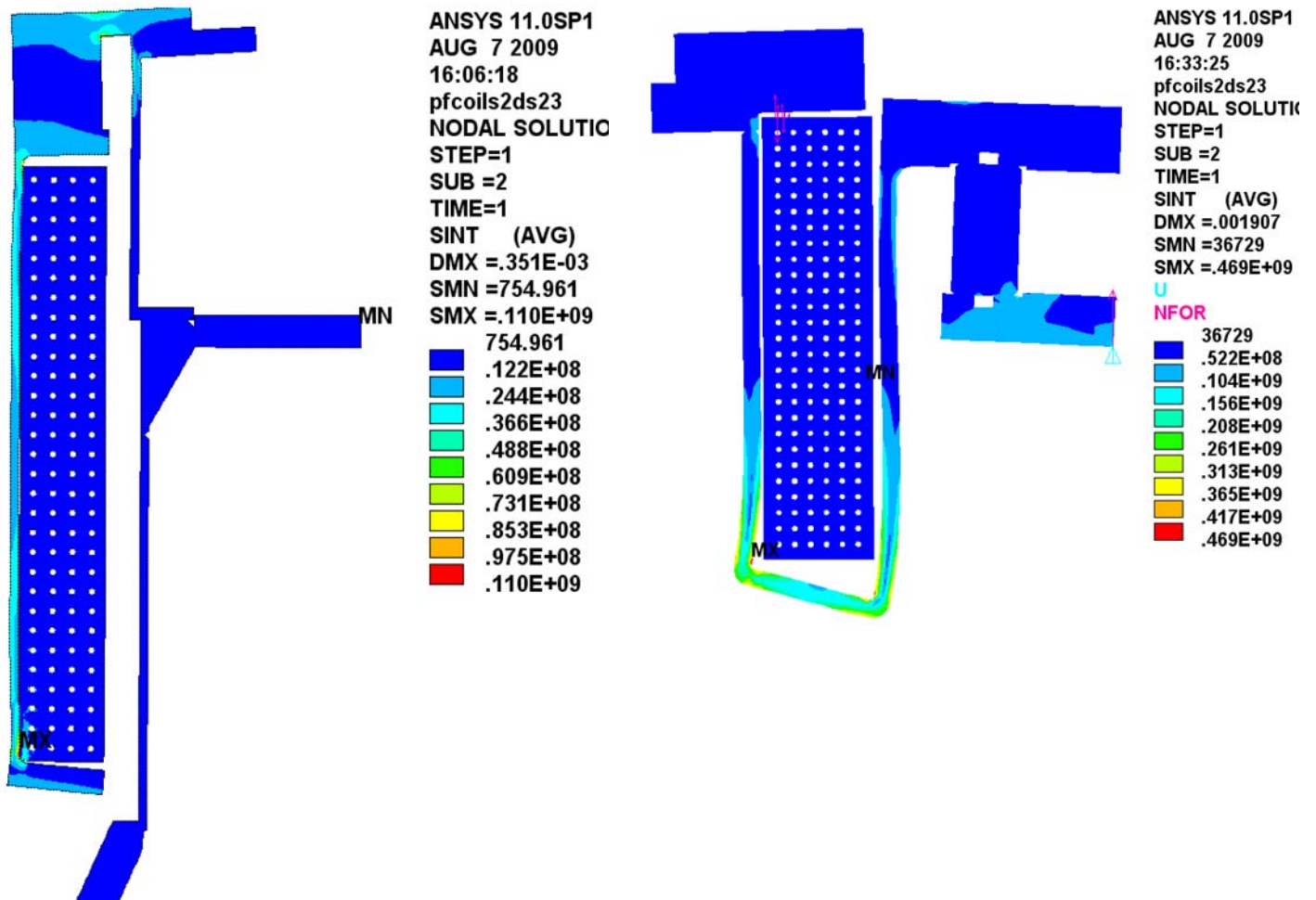

The PF1 Cu conductor stress is shown in the left plot of Fig. 3.1-2 for Equilibria #1 (E1). The legend indicates a max Tresca stress of 67 MPa (10 ksi). The right plot of Fig. 3.1-1 shows a close-up of the bottom 4x5 turns of PF1aU, where the coil rests against its bobbin flange. Away from the local contact, the Cu stress is well below 20 MPa. Recall that the allowable stress in the Cu is ~236 MPa.

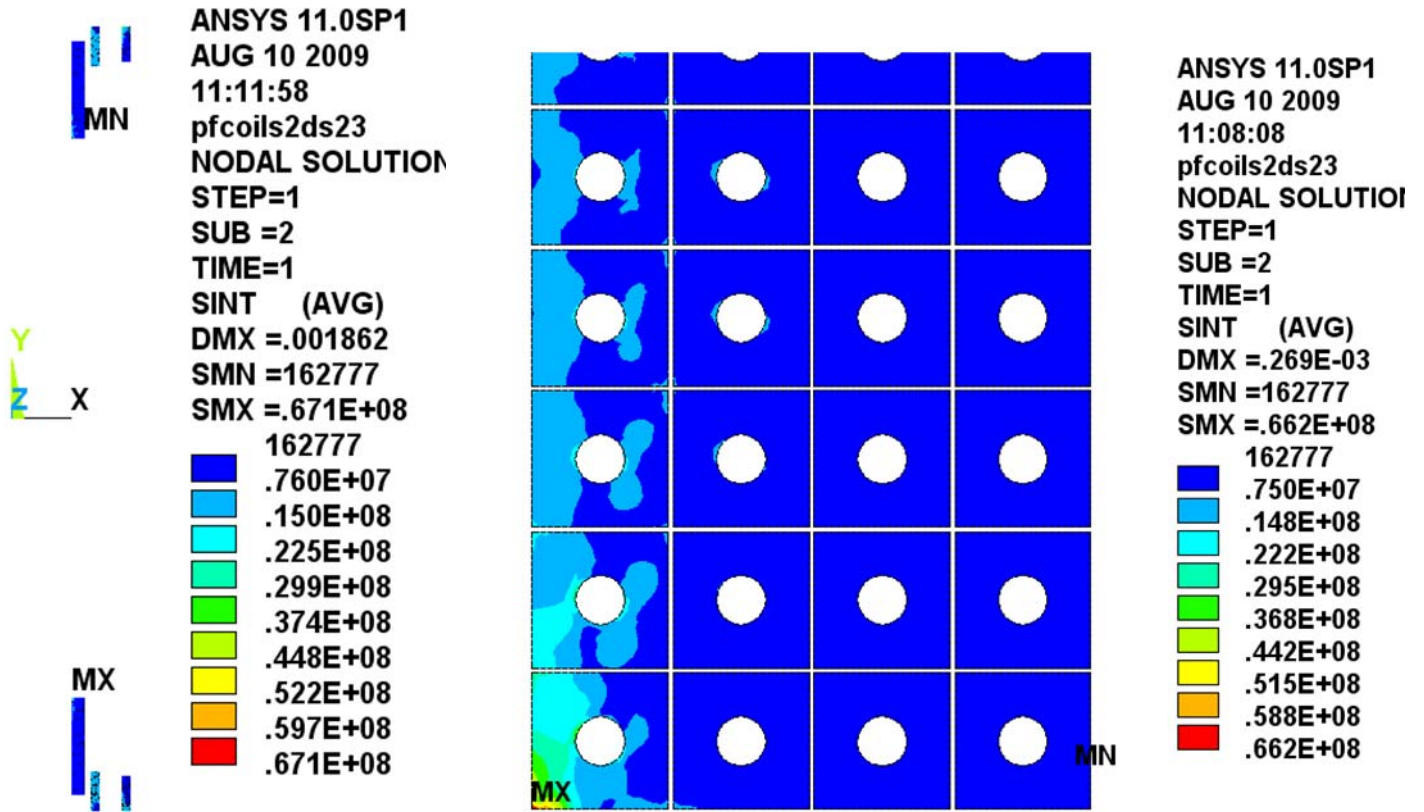

Fig. 3.1-2 Conductor Stress Plots

Left: All PF1 Conductors, Right: Close-Up of PF1aU Bottom ID Region

The PF1 insulation stress is shown in the left plot of Fig. 3.1-3 for E1. The legend indicates a max shear stress <13 MPa. The right plot shows a close-up of the insulation surrounding the 2x2 turns at the top-IR of PF1aL. The vectors represent nodal forces (the negative of the more typical reaction force) and highlight how the coil rests against the inner edge of the bobbin flange. Even with this local contact pressure, this shear stress is well below the nominal design limit of 22 MPa.

All 2D stress results are summarized in the bar chart of Fig. 3.1-4. Clearly, the PF1c case is an issue which must be addressed. Cu and insulation stresses are in reasonably good shape.

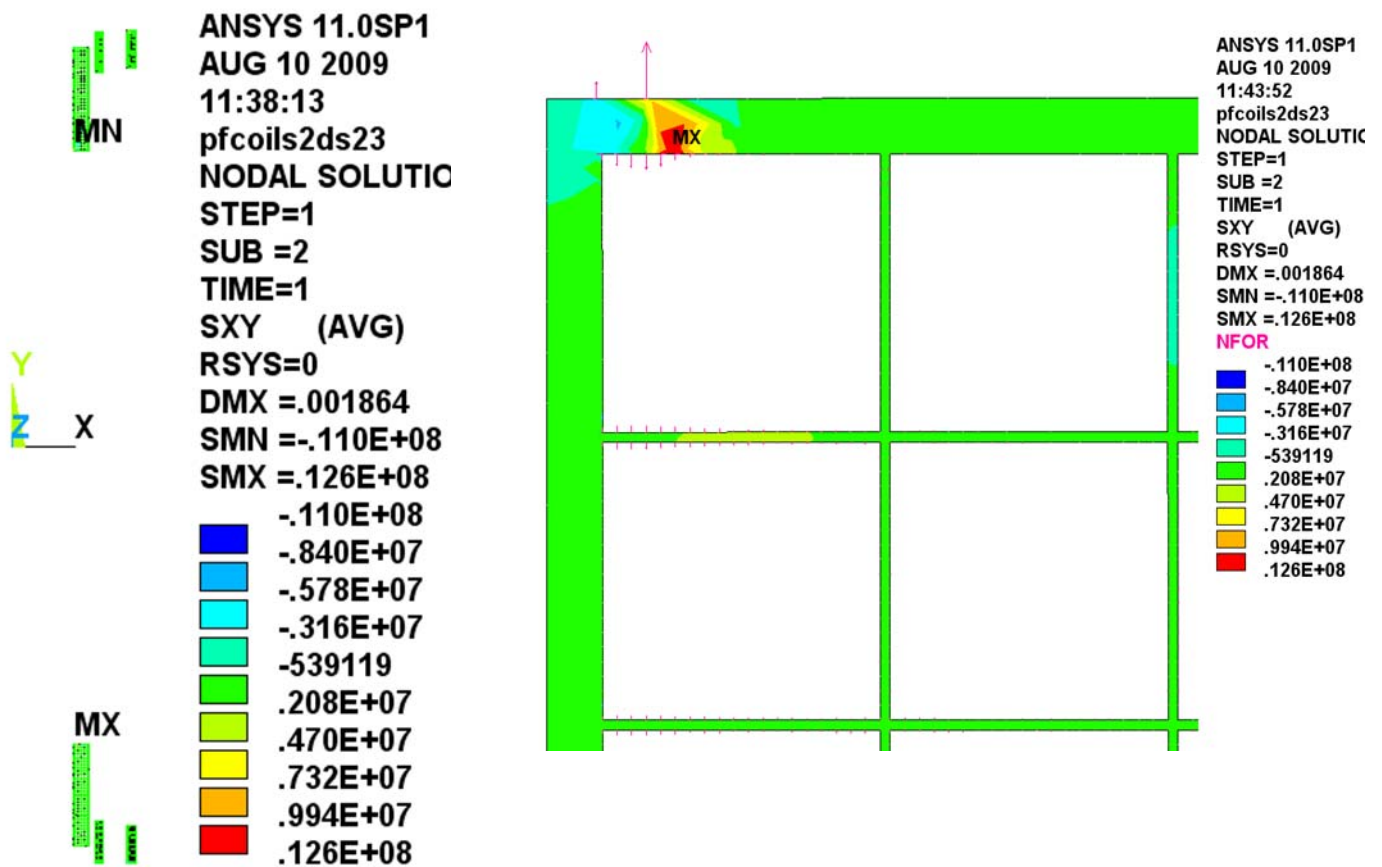
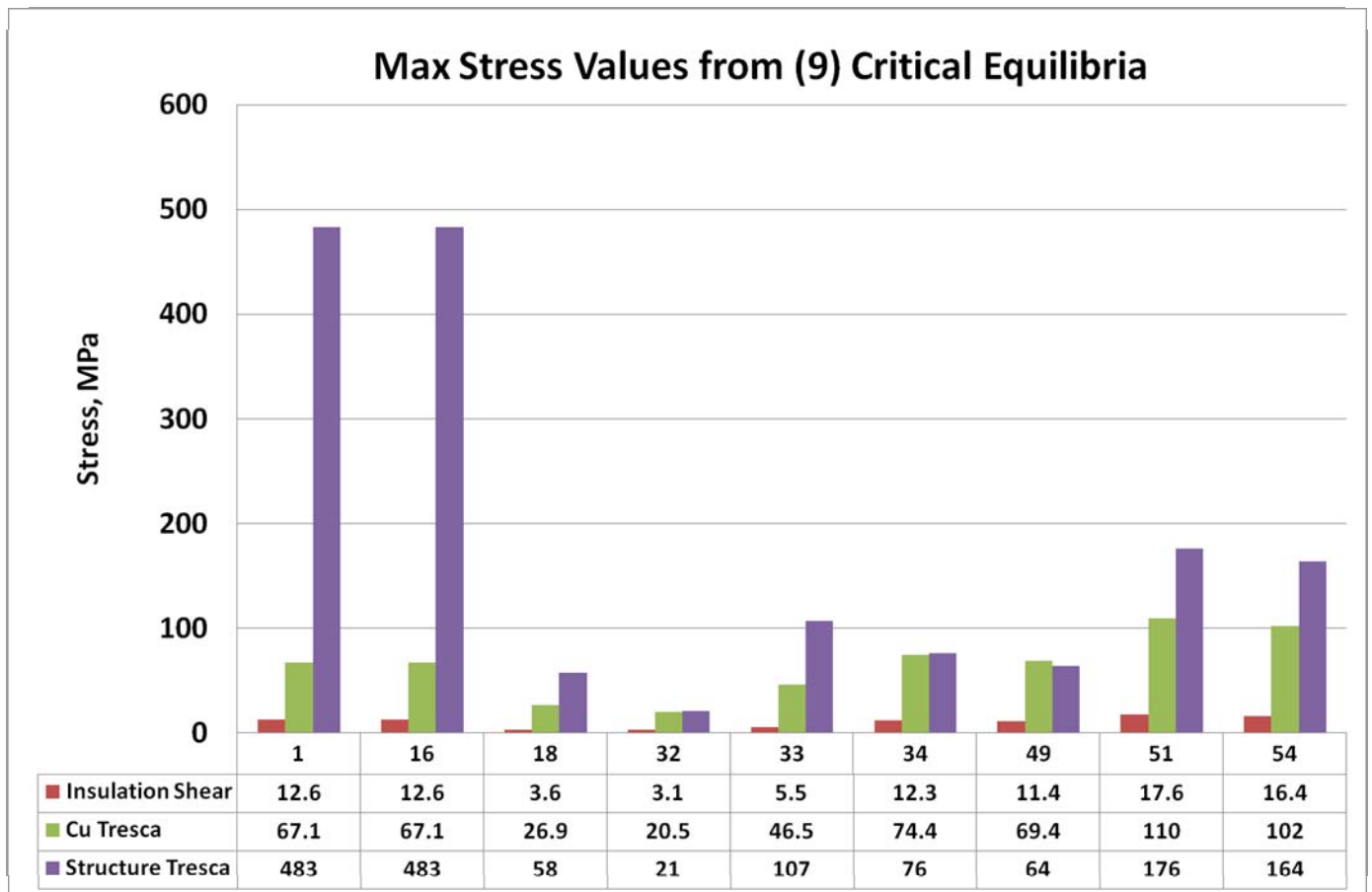

Fig. 3.1-3 Insulation Stress Plots

Left: All PF1 Conductor Insulation, Right: Close-Up of PF1aU Bottom ID Region

Fig. 3.1-4 Summary of 2D Stress Results



3.2 3D Stress Results

3.2.1 PF1a Structure

PF1a is secured to the PF1b bobbin through a welded ring and gusset structure. The net vertical force on the coil must pass through these gusset welds as a primary tensile stress. Fig. 3.2.1-1 shows the -100 kip load produces tensile stresses at the gusset welds of >450 MPa. When a $\frac{3}{4}$ " radius is added to the gusset, the stress drops by about 25%. In addition to the radius, consider making the gussets from $\frac{5}{8}$ " plate.

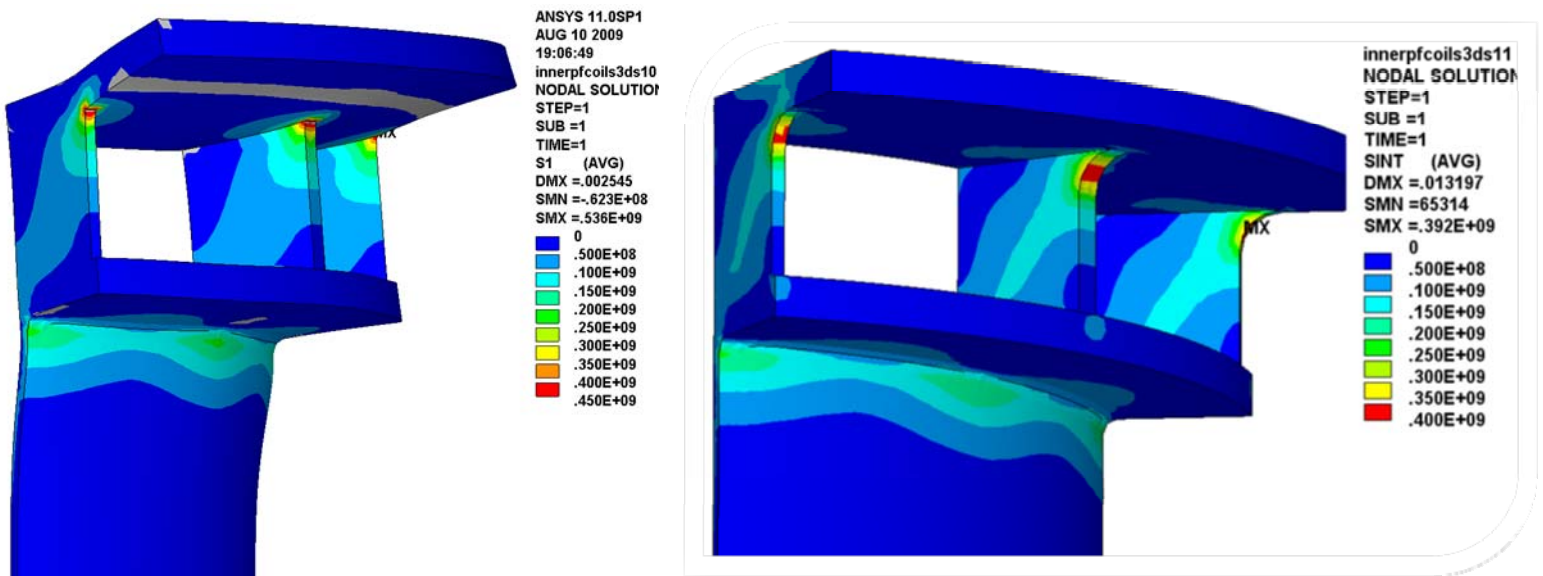

Fig. 3.2.1-1 PF1a Bobbin Structure Stresses (left: no gusset radius, right: $\frac{3}{4}$ " gusset radius)

3.2.2 Support Legs

The asymmetry in PF1a U & L coil currents produces a net load through the center stack support legs of ~70 kip. When the pad at the base is restrained vertically at a single point, the leg must carry the bending moment resulting from the jog in the load path. As shown in Fig. 3.2.2-1, this produces a bending stress of ~650 MPa. Dropping the stress in this material will require a re-design of the legs and the addition of some gussets above the support ring. This work is TBD.

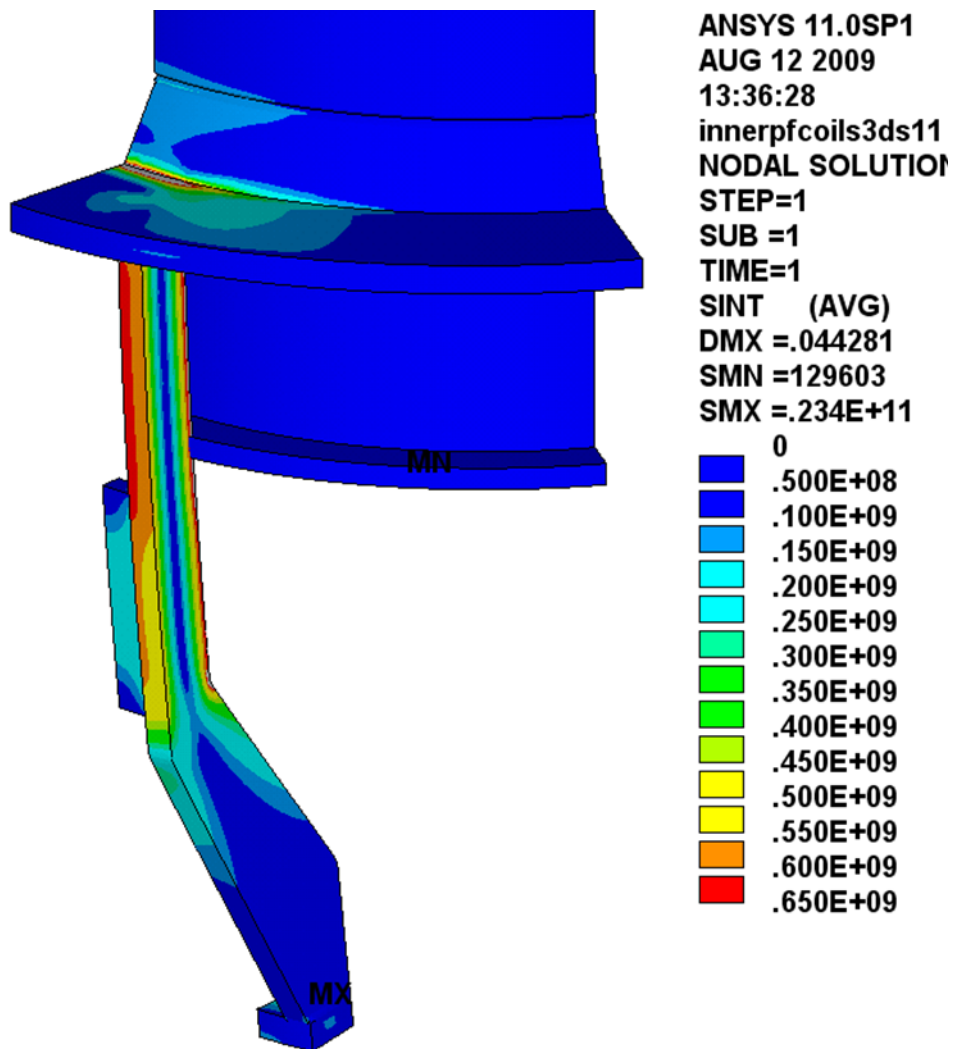
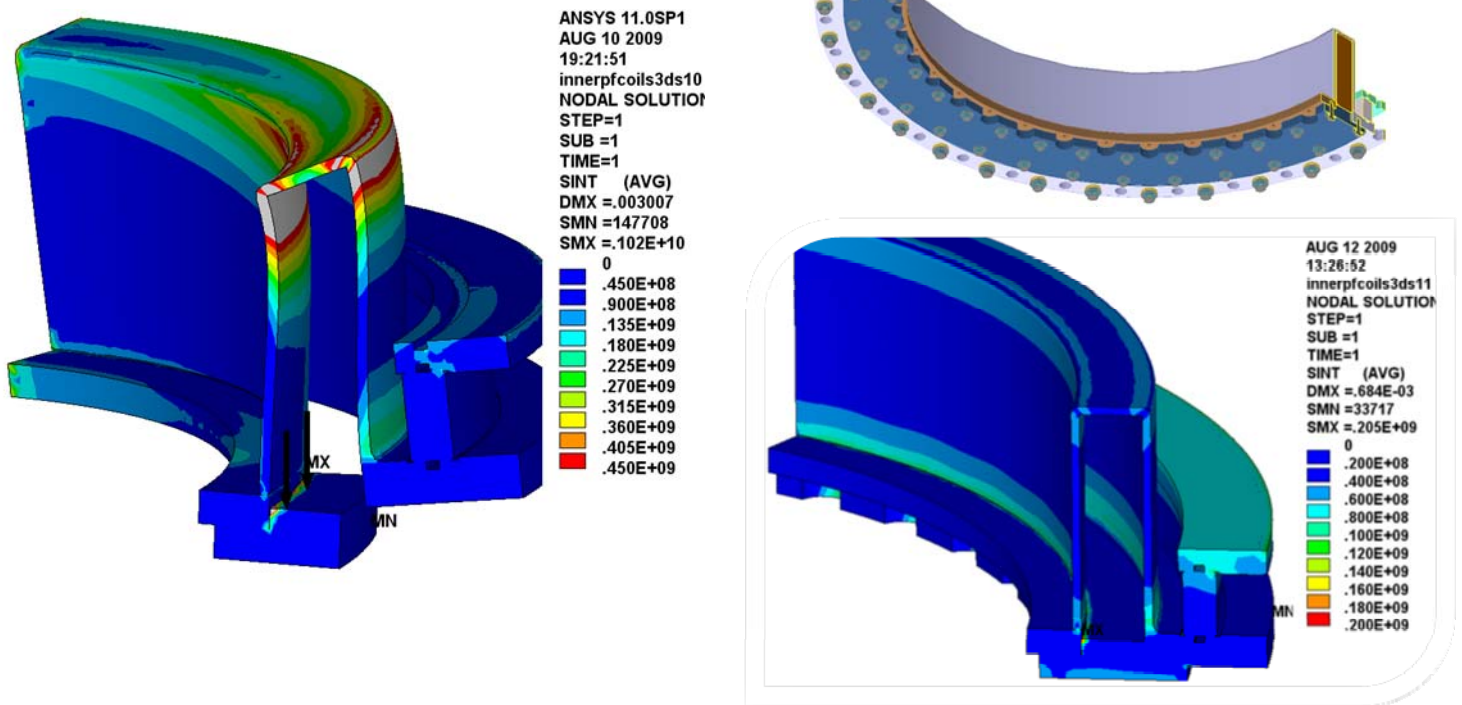

Fig. 3.2.2-1 Support Leg Stress

3.2.3 PF1c Case

The 80 kip launching force on PF1c has to be carried by four brackets. (I use 1/6th symmetry and show half of a bracket here, so I really only model three brackets). Contours run from zero to 450 MPa (Sy for Incoloy 625) in Fig. 3.2.3-1. Grey regions exceed this yield stress value, and highlight the extent of the problem region. The bracket is effectively bonded to the ID flange. So the model completely misses the loads on the bolts which hold one to the other. Replacing the brackets with a full ring-shaped cover bolted to the coil case flange would solve this stress problem. L. Morris' revised design shown here drops stress to ~150 MPa.

Fig. 3.2.3-1 PF1c Case stresses without (left) and re-designed with cover plate (right)



4.0 Results Summary

The 2D stress analyses indicate:

1. 80 kip launching force in PF1c requires a more robust hold-down design to stiffen the open coil case. A full cover is recommended. Analysis TBD.
2. The 100 kip centering force in PF1a produces some bobbin flange deformations which would benefit from a slight increase in their thickness or stiffening gussets. Analysis is TBD.
3. Cu and insulation stresses are generally OK, but would gain some margin with any increases to the structure discussed here.

The 3D stress analysis indicates:

1. The PF1a structure (gussets) should be thickened and radiused.
2. The net vertical loads which pass through the three legs produces some large bending stresses which must be addressed with a design/analysis cycle.
3. The PF1c case needs a full cover with ID & OD bolt circles.
4. Differential thermal strains can lead to high bending stresses in the shell structure. More detailed thermal stress analyses are TBD.