

NEUTRAL BEAM ARMOR

VDE Electromagnetic Disruption Analysis

With corresponding
Transient Dynamic and Static Stress Analysis

- **Apply the previous Finite Element Model for The Armor Eddy Current Analysis**
 - Include the Reactor Vessel with the Armor plate
 - Show Mesh Density and Boundary Conditions
 - **Apply Disruption Case of Magnetic Vector Potential from Opera Data Tables**
 - Data tables of Magnetic vector Potential (provided by others) are contoured as inputs to this analysis.
 - Magnetic Flux B Field is contoured on the FE model as the curl of the applied vector potentials
 - Contour the voltage across the Armor during the disruption event
 - Compare the B Field calculations from the updated ANSYS script with the OPERA results
 - **Provide Magnetic Results for:**
 - Current density at three discrete locations as a function of time.
 - Trend identifies the critical time step during the disruption event
 - Current Density as a Vector Plot.
 - This result shows directional trends of current (entry and exit points) during the disruption
 - Provide Flux Density versus time and the time gradient of flux versus time at several locations
-
- **Apply the previous Finite Element Model for Static & Transient Structural Results**
 - Show the mesh and Structural Boundary Conditions
 - **Provide Transient Structural results for:**
 - Max Displacement at highest disruption event load step
 - Contour results for von Mises stress and Transient stress trends during the disruption event
 - Reaction Load Magnitudes and a comparison for each load step
 - **Provide Static Structural Reaction Load results at each load step**
 - Contour results for von Mises stress and stress trends during the disruption event loads
 - Compare the Reaction Loads for Static and Dynamic results for each load step
 - **Provide Conclusions and Recommendations**

ASSUMPTIONS

- **Magnetic Vector Potential Data Tables:**
 - 2-D Opera Results uniformly expanded into 3-D as provided by Ron Hatcher through Srinivas Avasarala e-mail dated 2-19-10 as “VDE cases”
 - The ANSYS APDL Load Script (and the underlying assumptions) is valid for these cases
 - Infinite Wire field (Volume II Lectures on Physics (R. Feynman) Equation 14.21 is added by superposition
 - Variations between Opera B field and Bdot calculations and the ANSYS is within tolerance
 - Opera Data for VDE encompasses Max disruption load case
 - ANSYS Element Solid 97 Classic Formulation
 - **Voltage at Vessel Boundary assumed to be zero potential**
 - (Historically the boundaries were coupled)
- **All Components are Merged Integral Solids from Pro-Engineer**
 - No gaps or other nonlinear material properties
 - Note: This will effect how load distributes through the structure.
 - Note: This artificially adds strength to the structure that does not in reality exist.
 - All Support Structure Braces are Merged Solids
 - Note: Reaction Loads and moments are only approximate – not for final design
 - Transient Dynamic Analysis assumes 0.5% structural damping
 - Symmetric boundaries assumed at cylindrical cut
- **Single Uniform Material Property : 304 Stainless Steel**
 - Uniform constant density and Isotropic material properties.
 - Temperature dependence is not included in this analysis

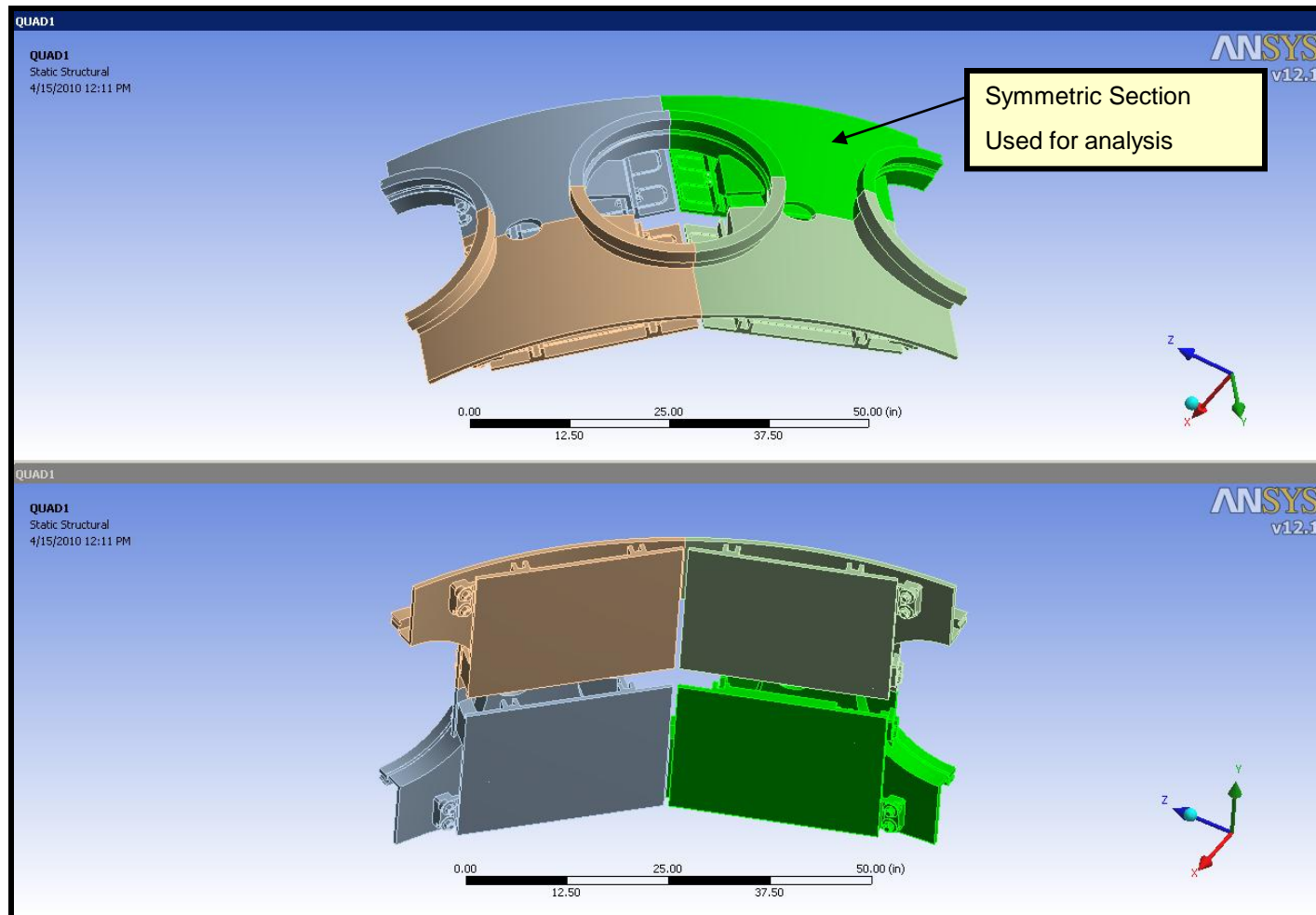

The Solid Model is Symmetric about 2 planes
Only $\frac{1}{4}$ of Armor model will be included in the FE analysis

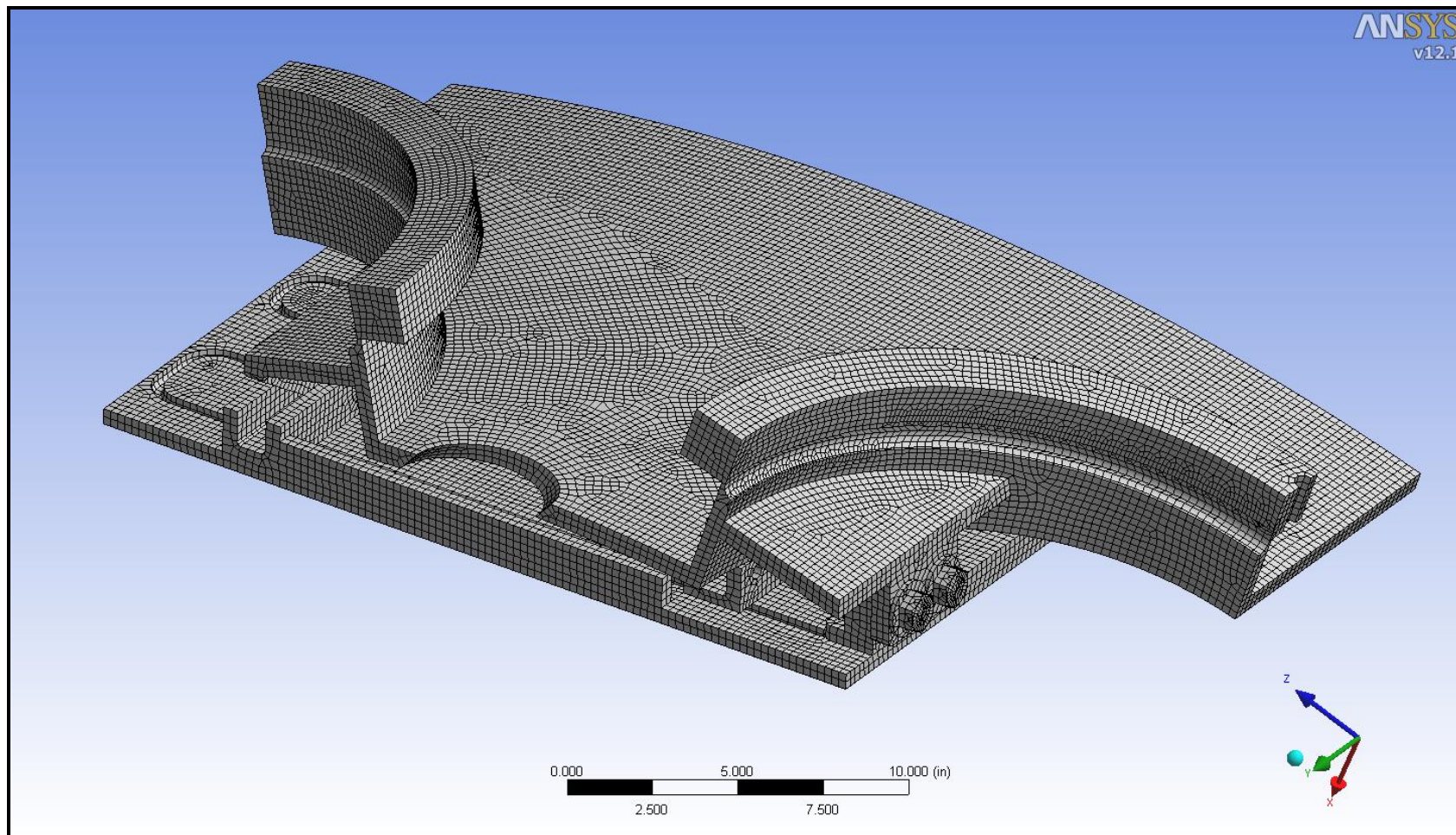

A High Density Hexahedral Element Mesh (Type 97)
Classic Formulation – Keyopt 1 = 1

Cylinder Boundary Set to Zero Voltage

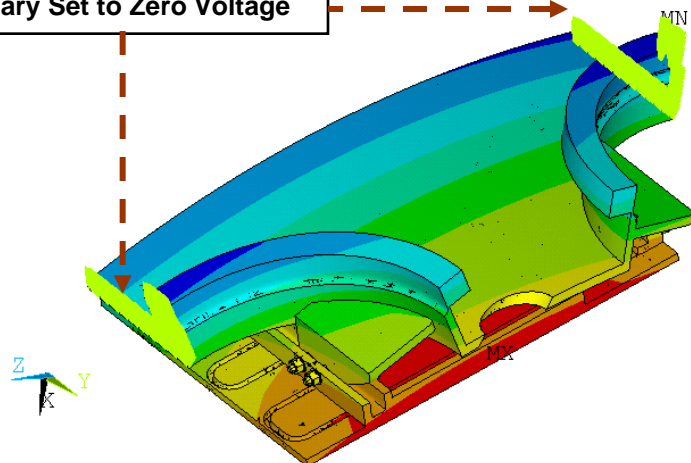

ANSYS

```

MAY 5 2010
15:49:43
NODAL SOLUTION
STEP=4
SUB =4
TIME=10.006
AY (AVG)
RSYS=5
PowerGraphics
EFACET=1
AVRES=Mat
SMN =-.833536
SMX =-.474448
VOLT
    
```

$$B_z = \nabla X A_z = \frac{1}{r} \frac{\partial(rA_\theta)}{\partial r}$$

A_θ from Opera program

2

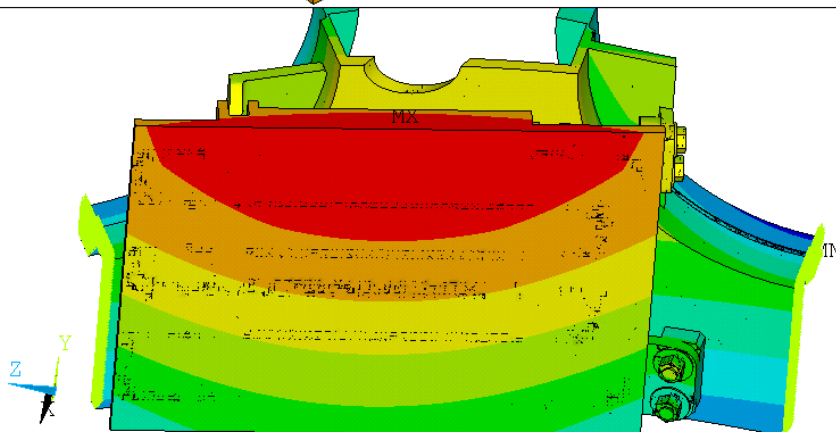

NEUTRAL BEAM ARMOR - VECTOR POTENTIAL

```

*ZF =.493506
A-ZS=-128.043
Z-BUFFER
-.833536
-.793637
-.753738
-.71384
-.673941
-.594144
-.554245
-.514346
-.474448
    
```

The hoop direction (AY) vector potential taken from Opera is the primary component contributing to the flux rate solution

Voltage Contour

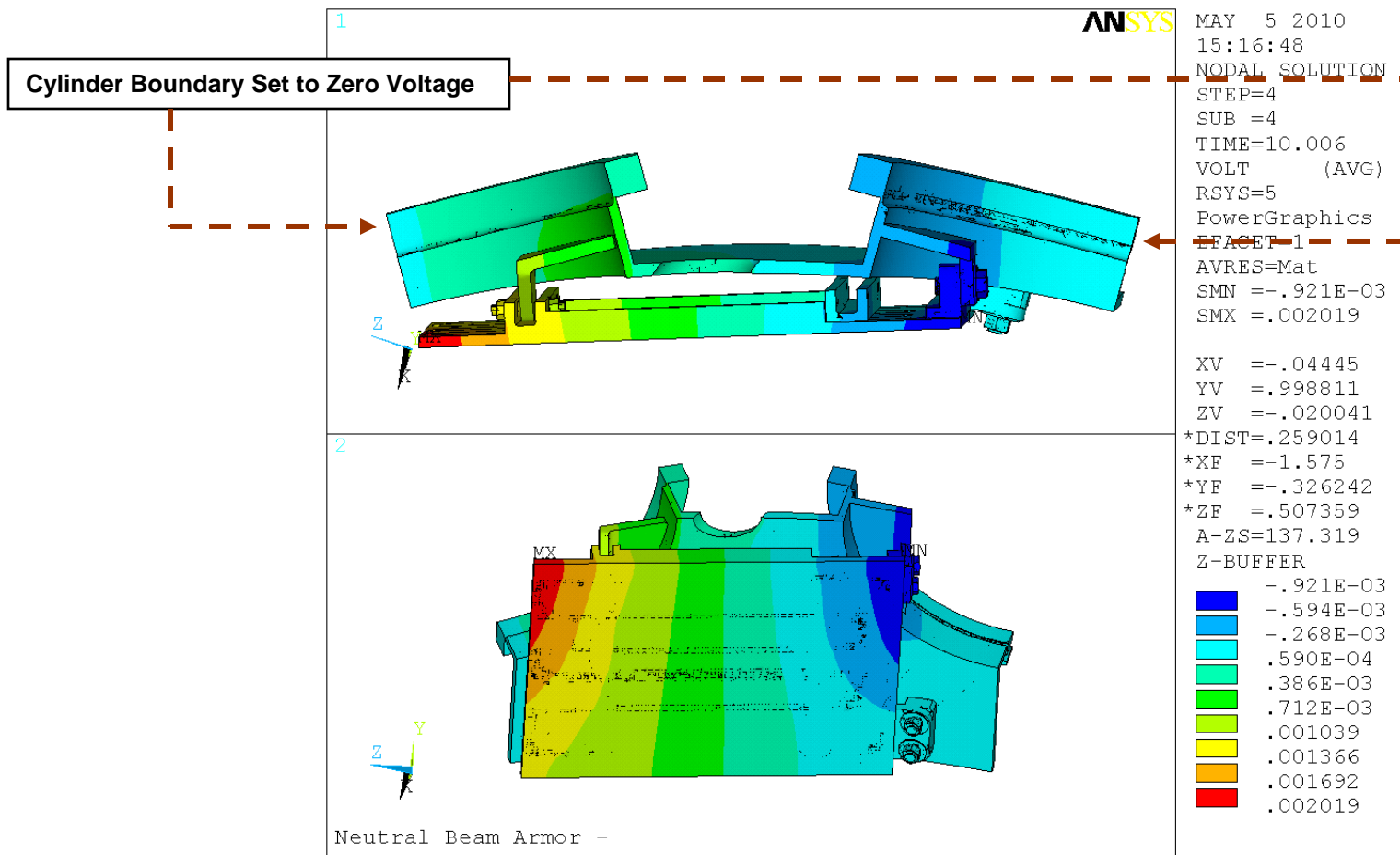

Voltage Contours (Volts) are banded and perpendicular to the current direction between armor supports during the disruption event

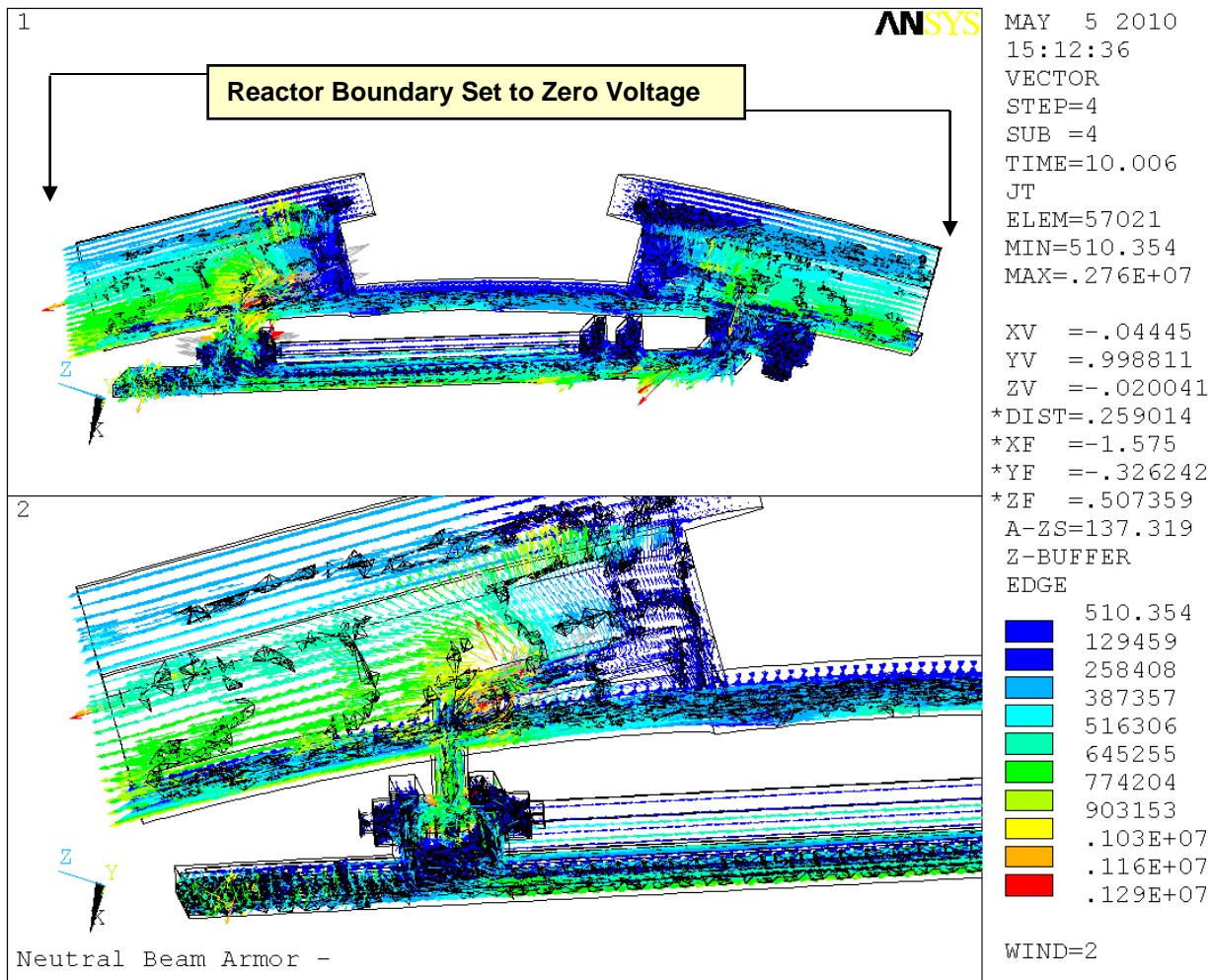

The Eddy Current Profiles Show Current Sharing
Normal Vector Profile at Voltage Boundary Condition

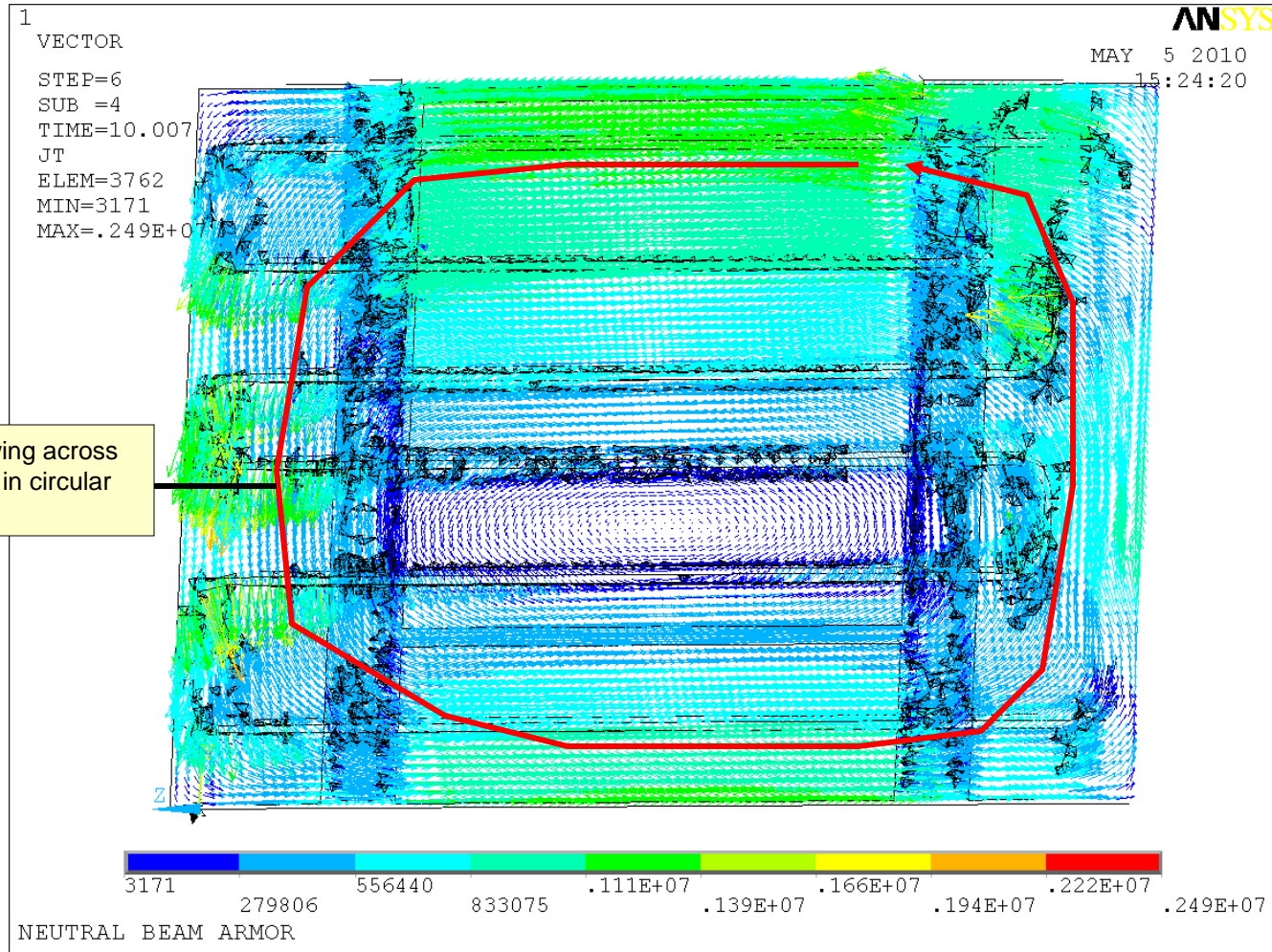

The Eddy currents circulate counterclockwise on the Armor surface

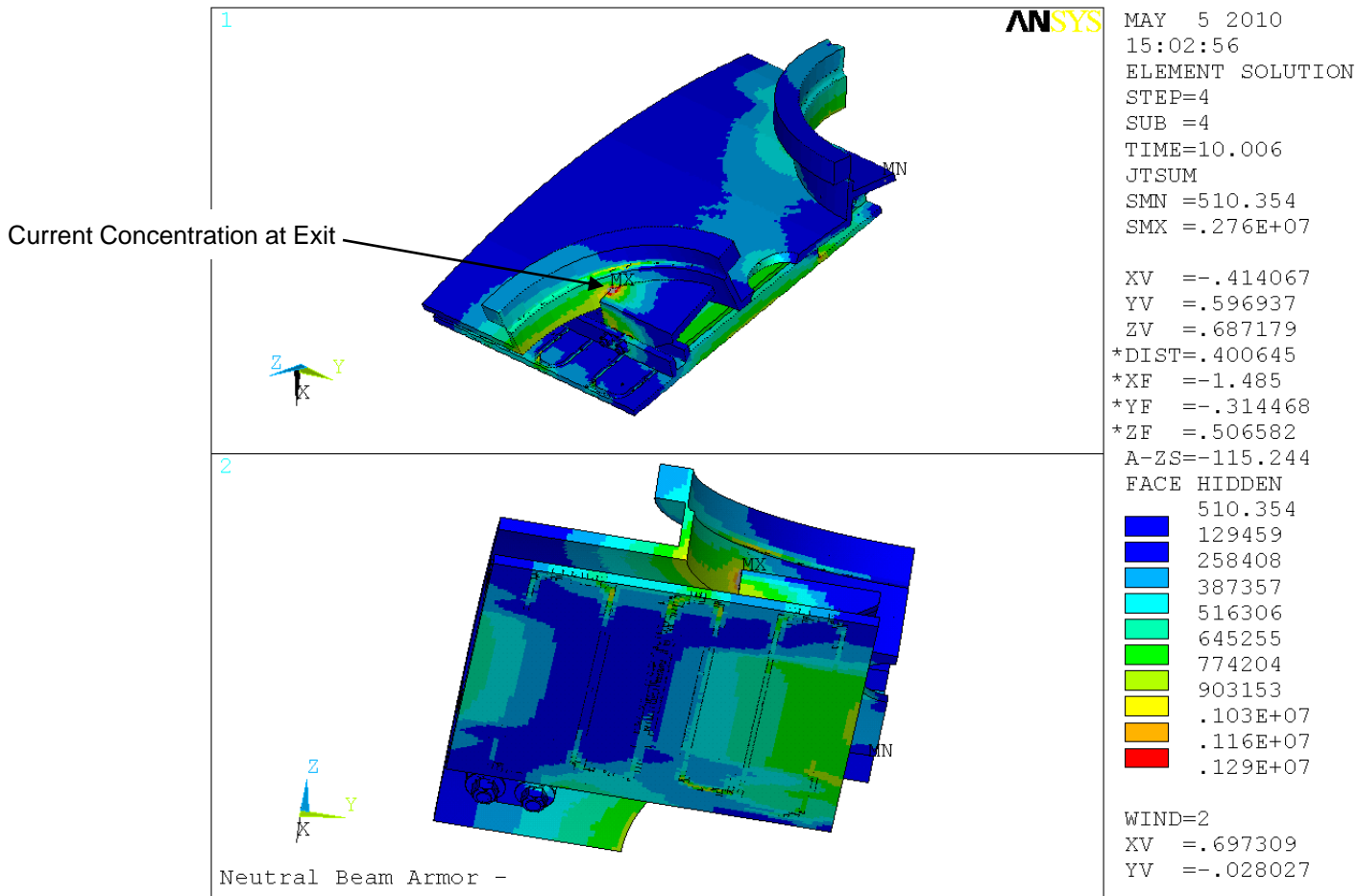

The max current density occurs as the current exits the Armor at the smallest section and sharpest corner through the bolt

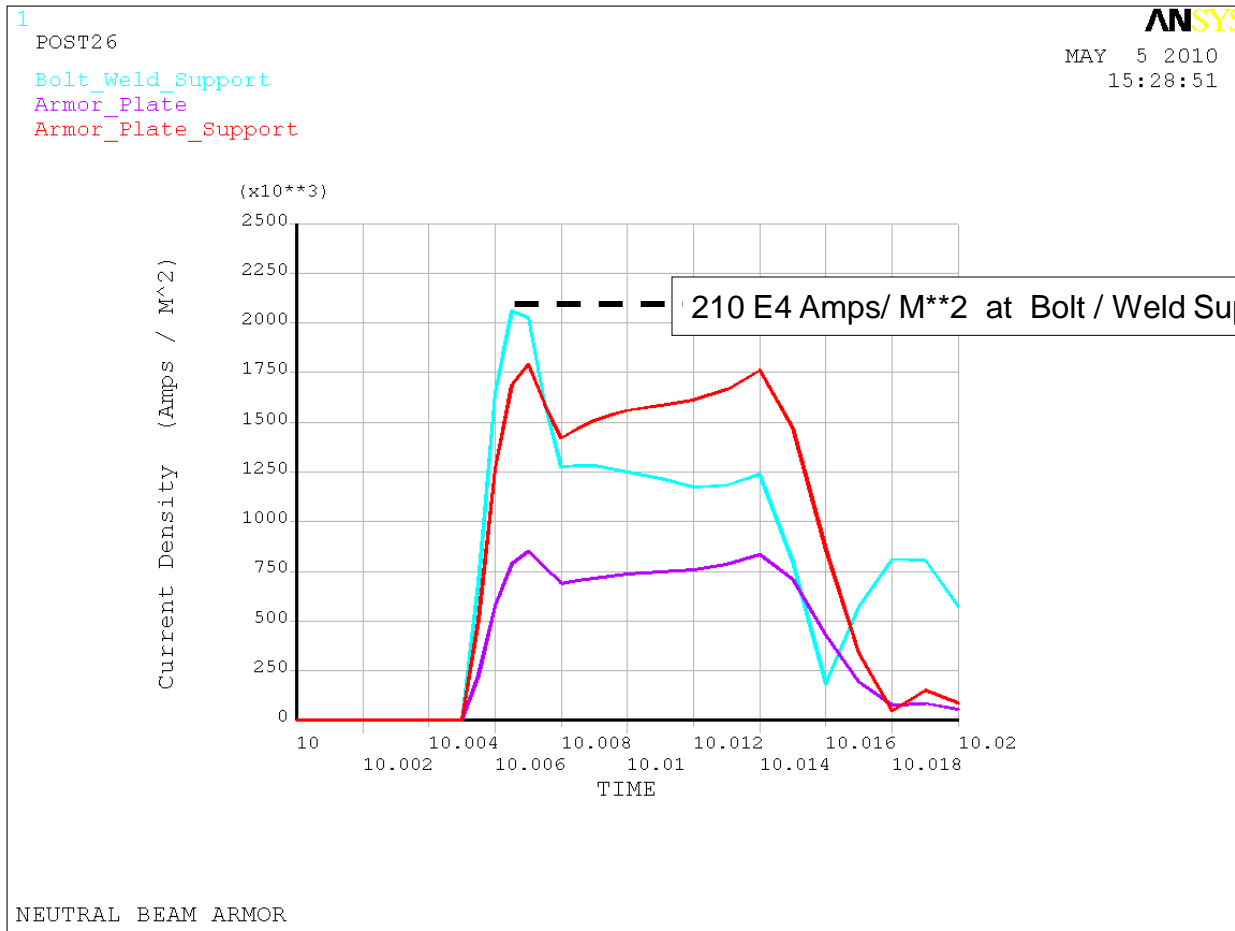

The Max Current Density Occurs at Time = 6.5 Milliseconds
 Vertical Disruption Profile

STATIC & TRANSIENT DYNAMIC STRUCTURAL ANALYSIS

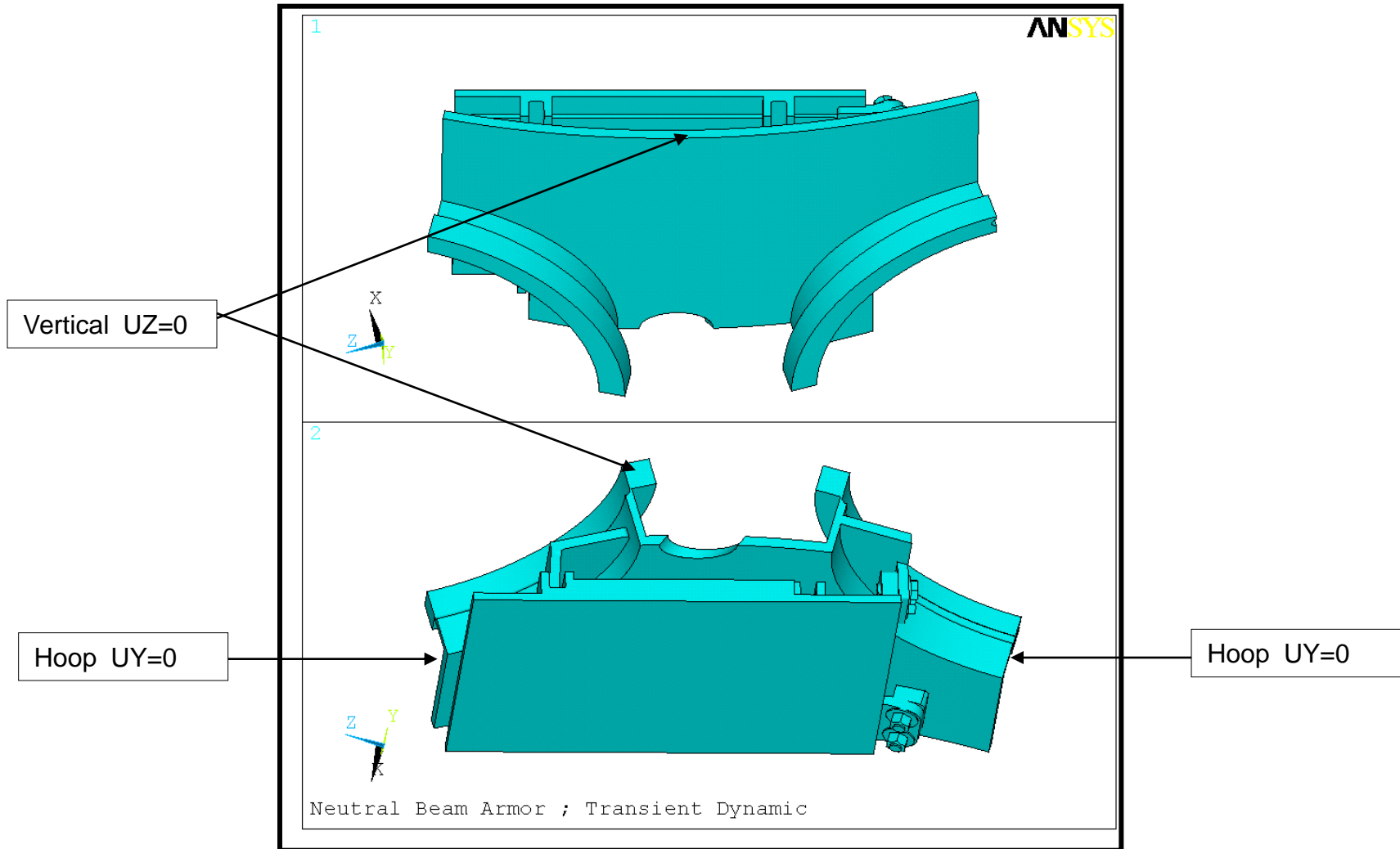

Structural Boundary Conditions Are Defined in Coordinate System 5 to match the Solid Model design

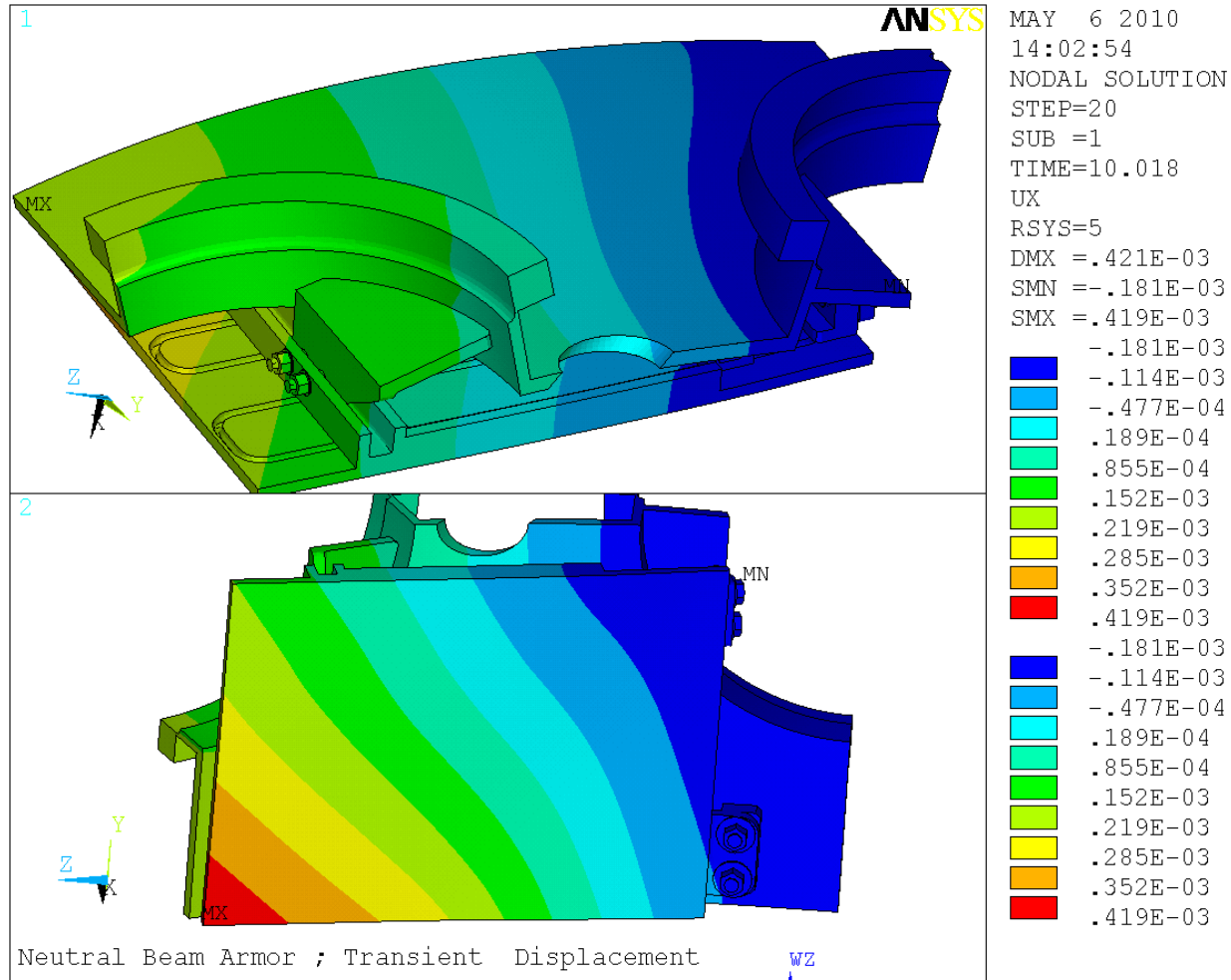

Note:
The assumed rigid structural deflections will be larger on actual model.
Units are Meters.

Transient Displacement at 18 Milliseconds after Initiation
Is symmetric on Armor Plate at .419e-3 m (16.49 mils)

Transient Max Displacement

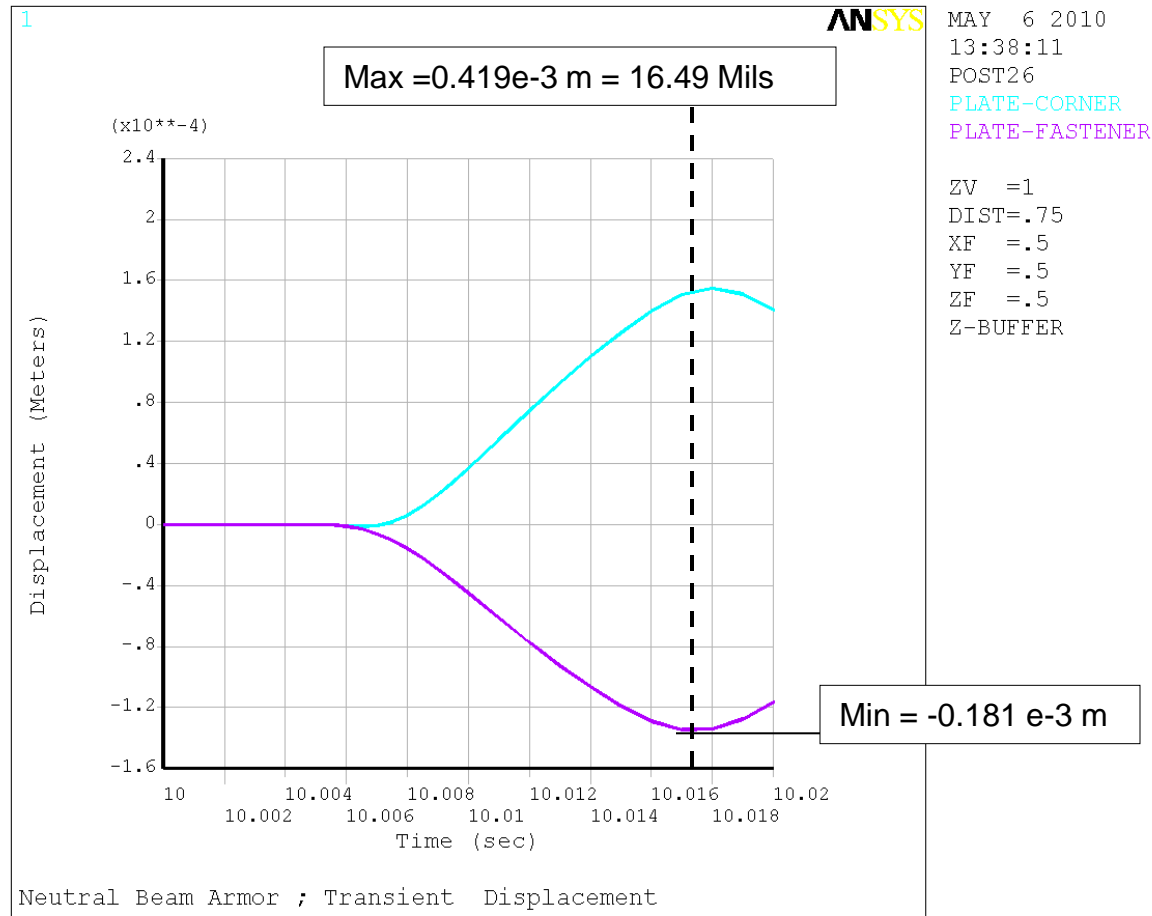

The Transient Displacement Results are Symmetric
(Based on Symmetric Structure and Merged Solids)

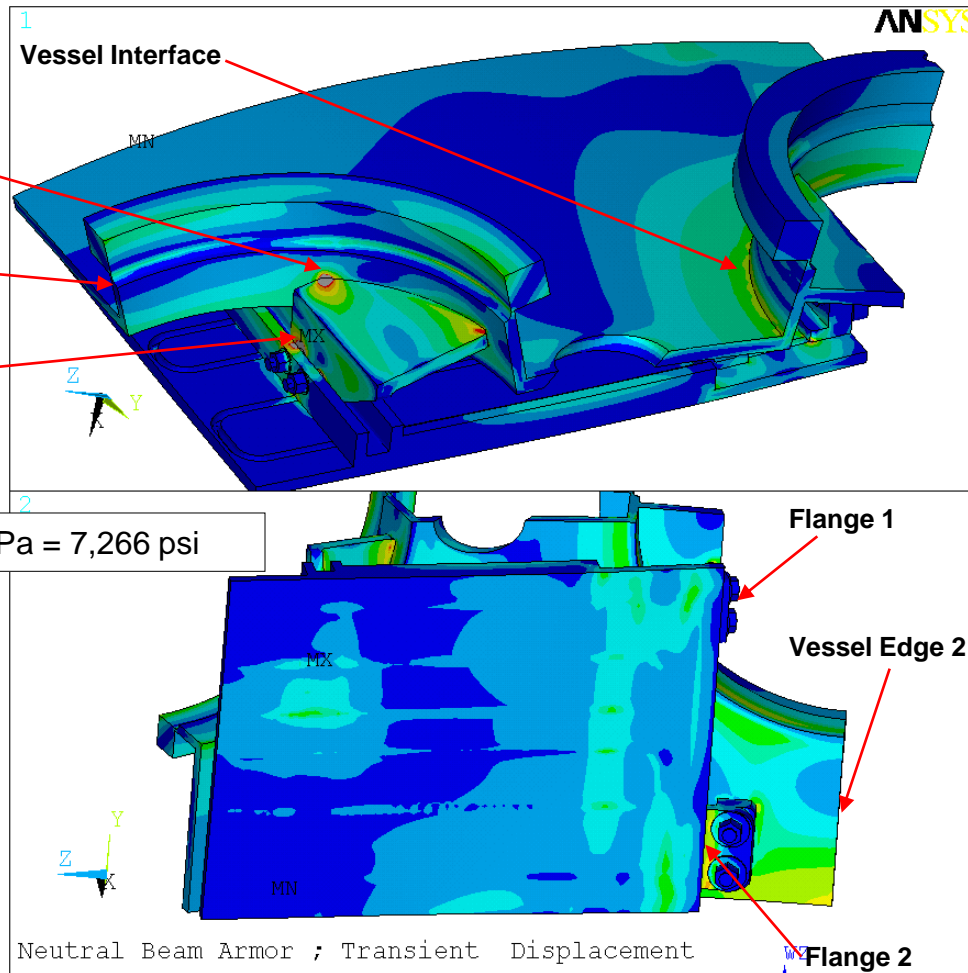

MAY 6 2010
13:53:17
NODAL SOLUTION
STEP=19
SUB =1
TIME=10.017
SEQV (AVG)
DMX =.431E-03
SMN =557.512
SMX =.501E+08
557

850529
.170E+07
.255E+07
.340E+07
.425E+07
.510E+07
.595E+07
.680E+07
.765E+07
.850E+07
.935E+07
.102E+08
.111E+08
.119E+08
.128E+08
.136E+08
.145E+08
.153E+08
.162E+08
.170E+08

The Transient Equivalent Stress at Max Current is less than 10 Ksi and well within the material strength capacity (Based on Merged Solids)

Transient Stress History

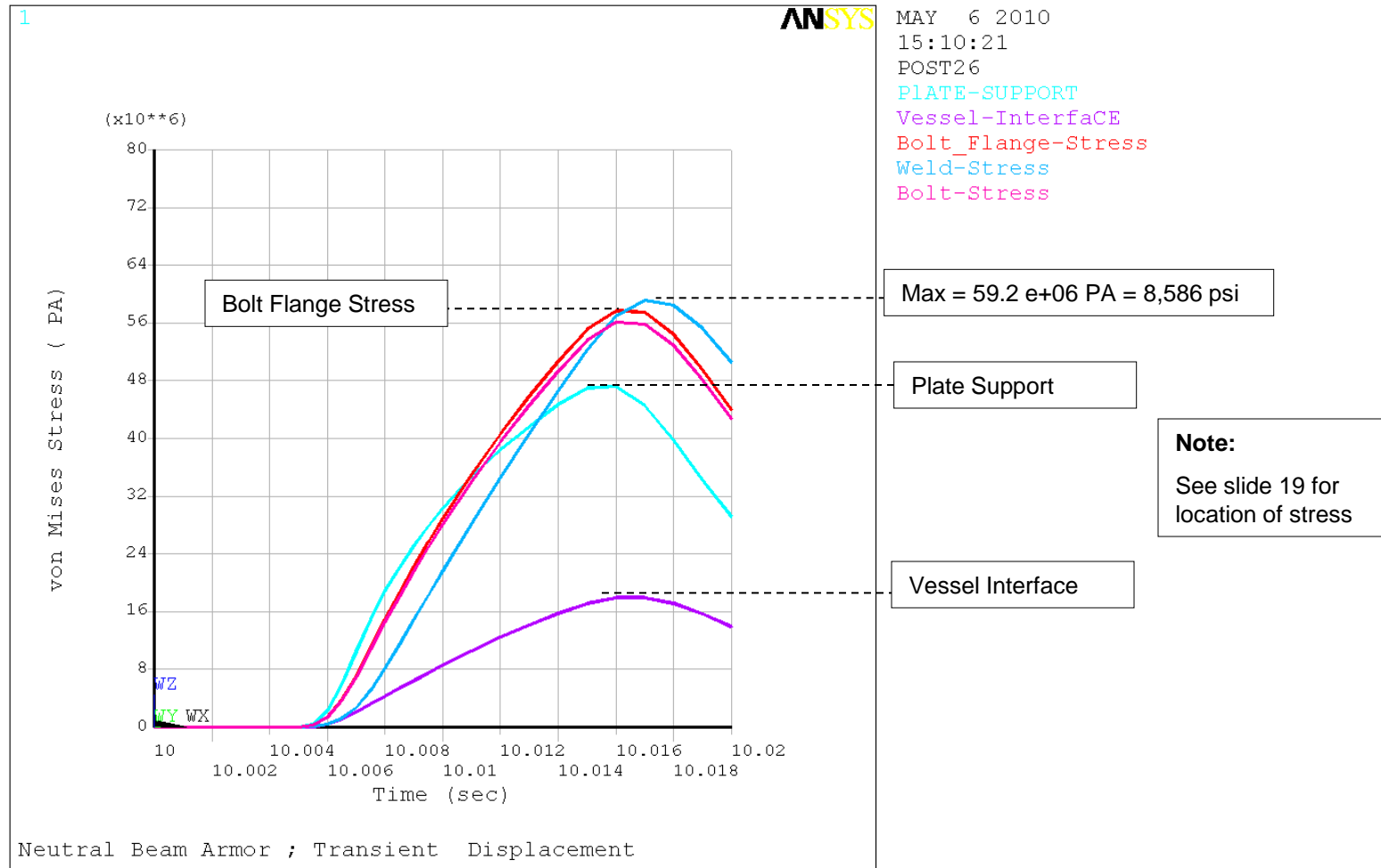

Typical Transient Stress Trends During Disruption
are low and well within the material strength capacity

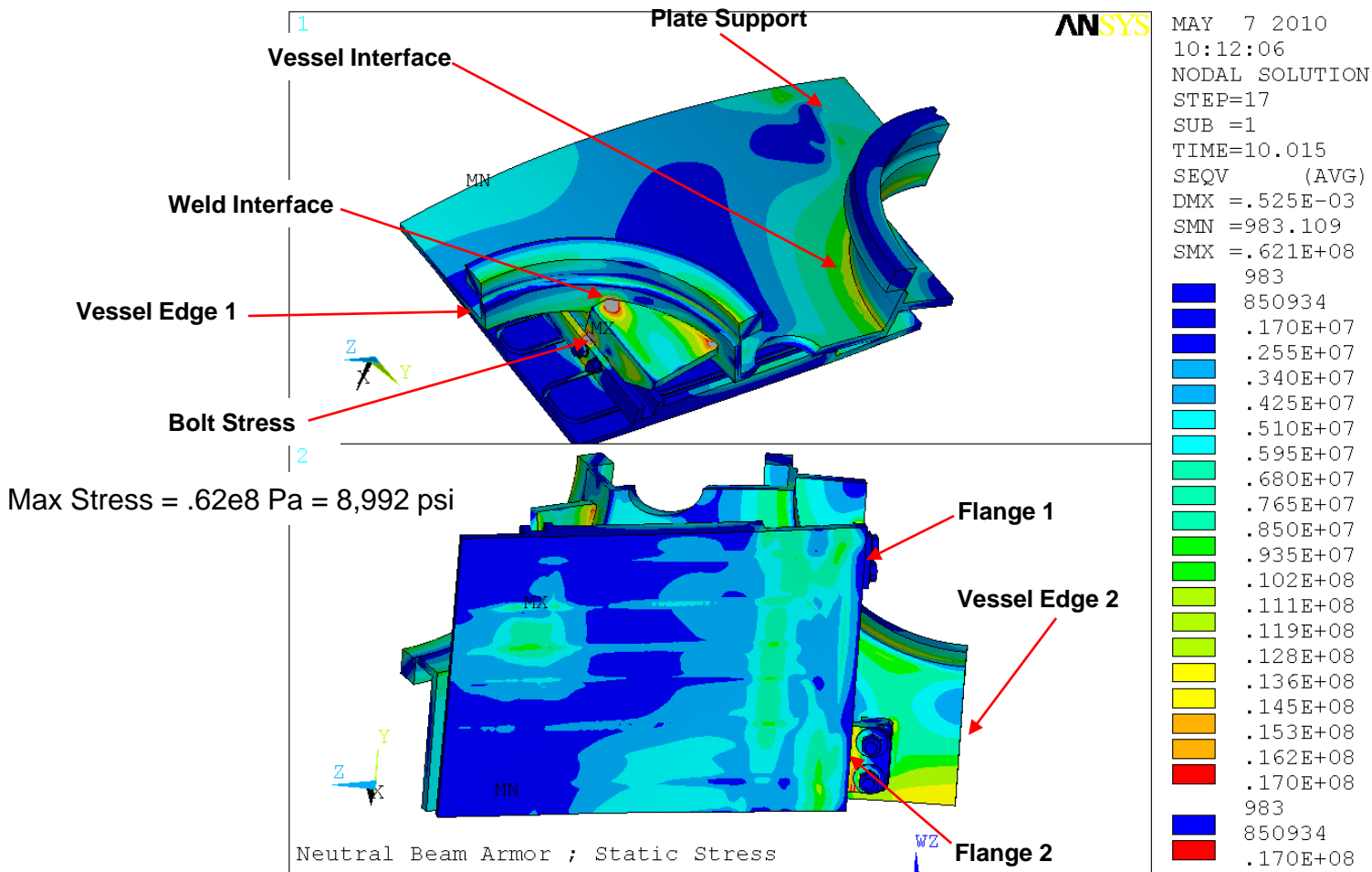

The Max Static Equivalent Stress at Max Current is 8.99 Ksi
This disruption profile is not significant for the Armor

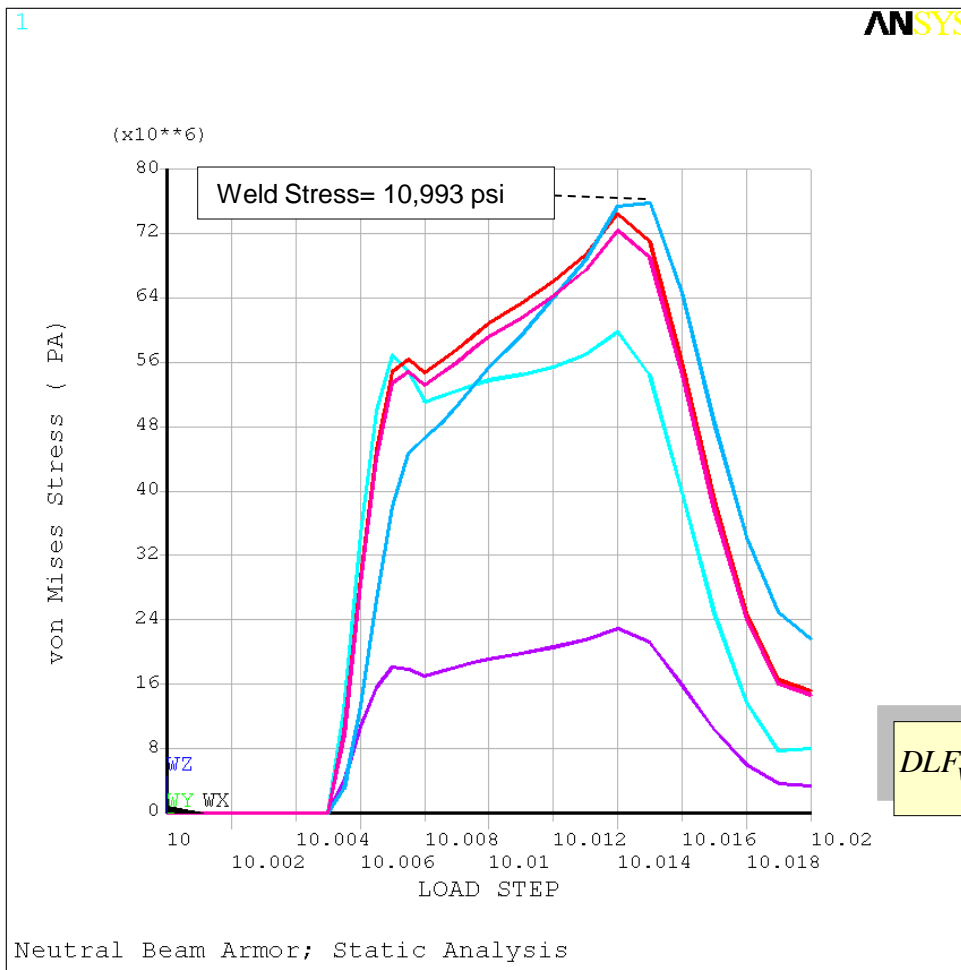

MAY 7 2010
07:39:01
POST26
PLATE-SUPPORT
Vessel-InterfaCE
Bolt_Flange-Stress
Weld-Stress
Bolt-Stress

Note:
The stress ratio would represent the
Dynamic Load Factor

$$DLF_{Weld} = \frac{U_{Static}}{U_{Dynamic}} \approx \frac{K\sigma_{Static}}{K\sigma_{Dynamic}} = \frac{10.993}{8.596} = \underline{\underline{1.278}}$$

Static Stress Variation for Disruption loads
The Dynamic Load Factor is approximately 1.278 on the weld Support

TRANSIENT REACTION

STATIC REACTION

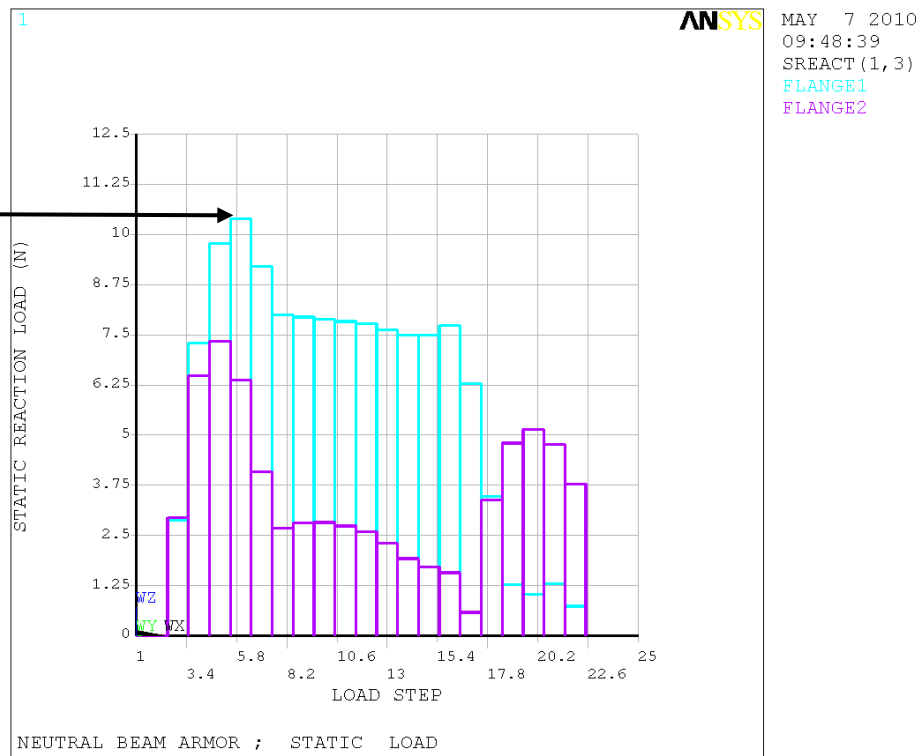
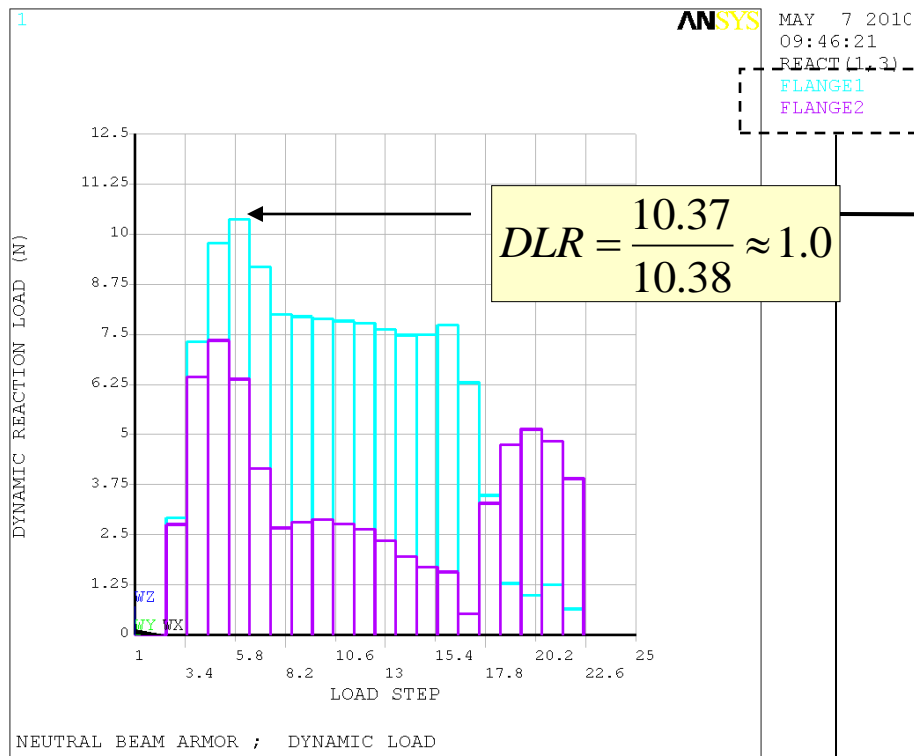

Note: Flange refers to the Armor attachment points

The Reaction Loads on the Vessel Boundary are low and very close in magnitude for the Vertical Disruption

0.87 < DLR for Attachment < 1.03

0.88 < DLR for Vessel Boundary < 1.32

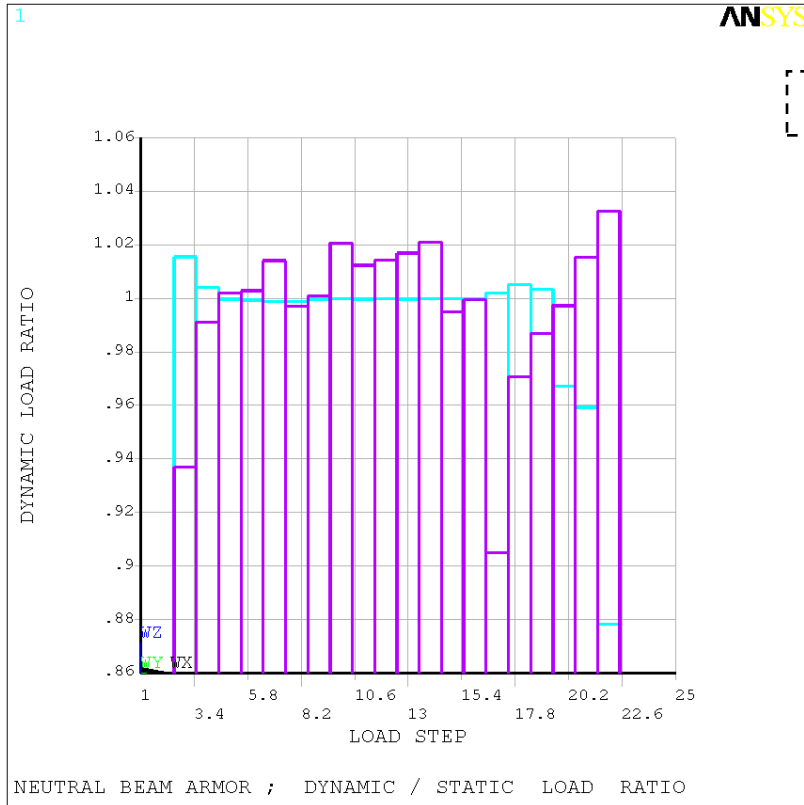

Note: Flange refers to the Armor attachment points

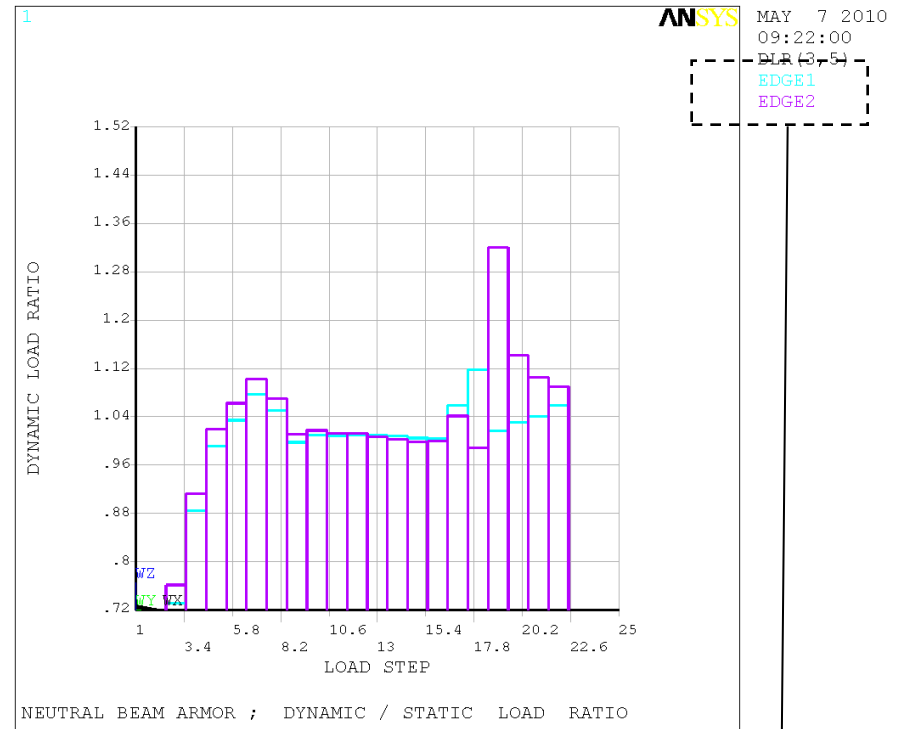

Note: Edge refers to the Reactor Vessel Cylindrical cut Boundary

The Dynamic Load Ratio for the two Armor Attachment Points Is lower than the reactor vessel cut boundary

CONCLUSIONS

- The Armor Electromagnetic, Transient Dynamic and Static Structural analysis is complete based on the best OPERA information available as of today and the assumptions of the merged solids.
- Induced Eddy currents were shown to transverse the Armor plate diagonally between the attachment points.
- The max current density (210 to 276 E4 Amps /M²) occurs 0.006 seconds into the disruption event.
- The max transient stress (8,586 psi) and X displacement (16.49 Mils) occurs at 17 seconds into the disruption event. These stresses are very low for the materials.
- The max static stresses (10,993 psi at load step 17) for the identical transient loads show that this disruption profile is not significant and that the effective time constant is lower resulting in similar load reaction magnitudes between transient and static load cases.
- The reaction loads are very small at the armor attachment points to the vessel hoop loads and the vessel boundary. This demonstrates that the longer time duration of the disruption event does not necessarily imply that reaction load magnitudes will be greater.
- The reaction load ratio (dynamic / static) is lower for the Armor Attachment points when compared to the reactor Vessel boundary.
- The Dynamic Load Factor on this Merged solid is 1.278 on the plate Supports. This value would change if flexibilities were included with a realistic and unmerged solid.
- The stresses from these loads are less than 10 ksi and well within the material capacity of 304 Stainless steel based on all the assumptions such as merged solids. This could have significant effects on how loads are distributed.

RECOMMENDATIONS

- Complete the final Passive Plate disruption runs to compare with this analysis. This work is currently in progress.
- Complete the thermal modeling on the armor to fully capture the max thermal gradient and increases in load as electrical resistivity changes.
- Expand the structure runs to include sub models on the weld attachment points and bolts. The stresses are low in these results, however, if a large load is in reality directed preferentially through one support (load follows stiffness) the stresses may be very concentrated at one location. This is not included in this analysis.
- Evaluate reductions in the stiffness on this structure by unmerging the supports from the assumed rigid boundary and re-evaluating to assume that load is distributed as expected.
- Verify that each element in the Electromagnetic FE model has a rotated element coordinate system that matches the ANSYS nodal cylindrical coordinate system #5 to assure that induced disruption currents are aligned.
- Each analysis data set should provide a side by side comparison of the OPERA data for at least one point for B field and Bdot to validate the analysis inputs.

Show the foundations of the applied equations in the scripts used in the analysis

- Show the ANSYS Analysis Script with applied embedded equations
- Identify variables used to apply electromagnetic loads in the equations.
- Identify how the OPERA data is applied and what is calculated by ANSYS software
- Demonstrate from fundamental physics how the applied theory for the infinite wire is formulated.
- Show how the applied vector potential equation and Curl operator components are derived for use in the analysis script.
- Show how the Vector Potential equations are applied in the ANSYS analysis script on a simplified cylinder that approximates the reactor.

Internal PPPL Electromagnetic Script

```

timint,on
time,10.005
autots,on
deltim,.001,.0005,.002
kbc,0
*do,i,1,nmax
z=nz(i)
x=nx(i)
d,i,ay,vect5(x,z)
d,i,az,-0.5*BR*log(x*x)
*enddo
d,all,ax,0.
SOLVE

time,10.0055
autots,on
deltim,.0001,.00005,.0002
kbc,0
*do,i,1,nmax
z=nz(i)
x=nx(i)
d,i,ay,vect55(x,z)
d,i,az,-0.5*BR*log(x*x)
*enddo
d,all,ax,0.
SOLVE

```

Ay from Opera Tables

Az from assumption of infinite wire see derivation of this equation in next slide

Ax assumed = 0

The script applies only one value (Ay) from the Opera tables
Other values are calculated or assumed as zero

Ampere's Circuital Law

$$\oint \mathbf{B} \cdot d\mathbf{l} = \mu_0 I = \frac{I}{\epsilon_0 c^2} \quad I = \epsilon_0 c^2 B 2\pi r$$

$$j_z = \frac{I}{\pi a^2} \quad \text{uniform current density}$$

Assume: Infinite straight wire

$$A_z = \frac{-\pi a^2 J}{2\pi \epsilon_0 c^2} \ln(r) \quad A_z = -\frac{I}{2\pi \epsilon_0 c^2} \ln(r) \quad \text{REF : Feynman Eqn 14.21}$$

Substitute for I in terms of B:

$$A_z = \frac{\epsilon_0 c^2 B 2\pi r}{2\pi \epsilon_0 c^2} \ln(r) = Br \ln(r)$$

$$I = \left(\frac{130,000 \text{ Amps}}{\text{Turn}} \right) \left(\frac{12 \text{ Turns}}{TF} \right) \left(\frac{3TF}{\text{Turn}} \right)$$

Parameters for NSTX upgrade are known

$$A_z = \frac{I}{2\pi \epsilon_0 c^2} \ln(r) = \left(\frac{130,000 \text{ Amps}}{\text{Turn}} \right) \left(\frac{12 \text{ Turns}}{TF} \right) \left(\frac{3TF}{\text{Turn}} \right) \frac{2}{4\pi \epsilon_0 c^2}$$

$$A_z = \frac{2BR}{2} \ln(r) = \frac{(BR) \ln(r^2)}{2}$$

Addition of factor of 2 used since X coordinates in geometry must be > zero

The Derivation of the equation used in the script for the vector potential (A_z) is completed based on assumptions of Infinite wire and known operating parameters for the NSTX upgrade coil

- The dell operator on the vector potential can be defined as zero
 - Variation of A in theta are zero due to symmetry
 - Variation of A in vertical Z are zero due to symmetry
 - Variation of A in the radial are defined inversely as a function of radius r
 - Note: R. Feynman equation 18.23 does not make this assumption for Transient analysis**

$$\nabla \cdot A = 0 = \frac{1}{r} \frac{\partial}{\partial r} (rA_r) + \frac{1}{r} \frac{\partial A_\theta}{\partial \theta} + \frac{\partial A_z}{\partial z}$$

$$\nabla \cdot A = 0 = \frac{1}{r} \frac{\partial}{\partial r} (rA_r) + \frac{1}{r} \frac{\partial A_\theta}{\partial \theta} + \frac{\partial A_z}{\partial z}$$

Note: Transient analysis $\nabla \cdot A + \frac{\partial \phi}{\partial t} = 0$ we assume then that : $\frac{\partial \phi}{\partial t} = 0$

Although Classical Physics : $\nabla \cdot A = \frac{1}{c^2} \frac{\partial \phi}{\partial t}$ **R. Feynman eqn 18.23 Vol II Lectures on Physics**

- The assumption of a long straight wire with a steady current applies for applying transient boundary conditions as provided in Volume II Lectures on Physics (R. Feynman) Equation 14.21
- The B Field in ANSYS is calculated based on the reduction of the Curl Operator as:

$$B = B_x + B_y + B_z = -\frac{\partial A_\theta}{\partial z} i - \frac{\partial A_z}{\partial r} j + \frac{1}{r} \frac{\partial (rA_\theta)}{\partial r} k \quad \text{See derivation provided below}$$

Curl Operator Assumptions

$$B_x = \nabla X A_r = \frac{1}{r} \frac{\partial A_z}{\partial \theta} - \frac{\partial A_\theta}{\partial z} = -\frac{\partial A_\theta}{\partial z} \quad \text{since : } A_z \neq f(\theta) \text{ ; for symmetric profiles}$$

$$B_\theta = \nabla X A_\theta = \frac{\partial A_r}{\partial z} - \frac{\partial A_z}{\partial r} = -\frac{\partial A_z}{\partial r} \quad \text{since : } A_r \neq f(z) \text{ ; for symmetric profiles}$$

$$B_z = \nabla X A_z = \frac{1}{r} \frac{\partial(rA_\theta)}{\partial r} - \frac{1}{r} \frac{\partial A_r}{\partial \theta} = \frac{1}{r} \frac{\partial(rA_\theta)}{\partial r} \quad \text{since : } A_r \neq f(\theta) \text{ for symmetric profiles}$$

A_θ from Opera program

$$B = B_x + B_y + B_z = -\frac{\partial A_\theta}{\partial z} i - \frac{\partial A_z}{\partial r} j + \frac{1}{r} \frac{\partial(rA_\theta)}{\partial r} k$$

The theoretical B field from the Curl Operator
Is inconsistent with the resulting ANSYS contour plots

FE Model For Field Result Comparison

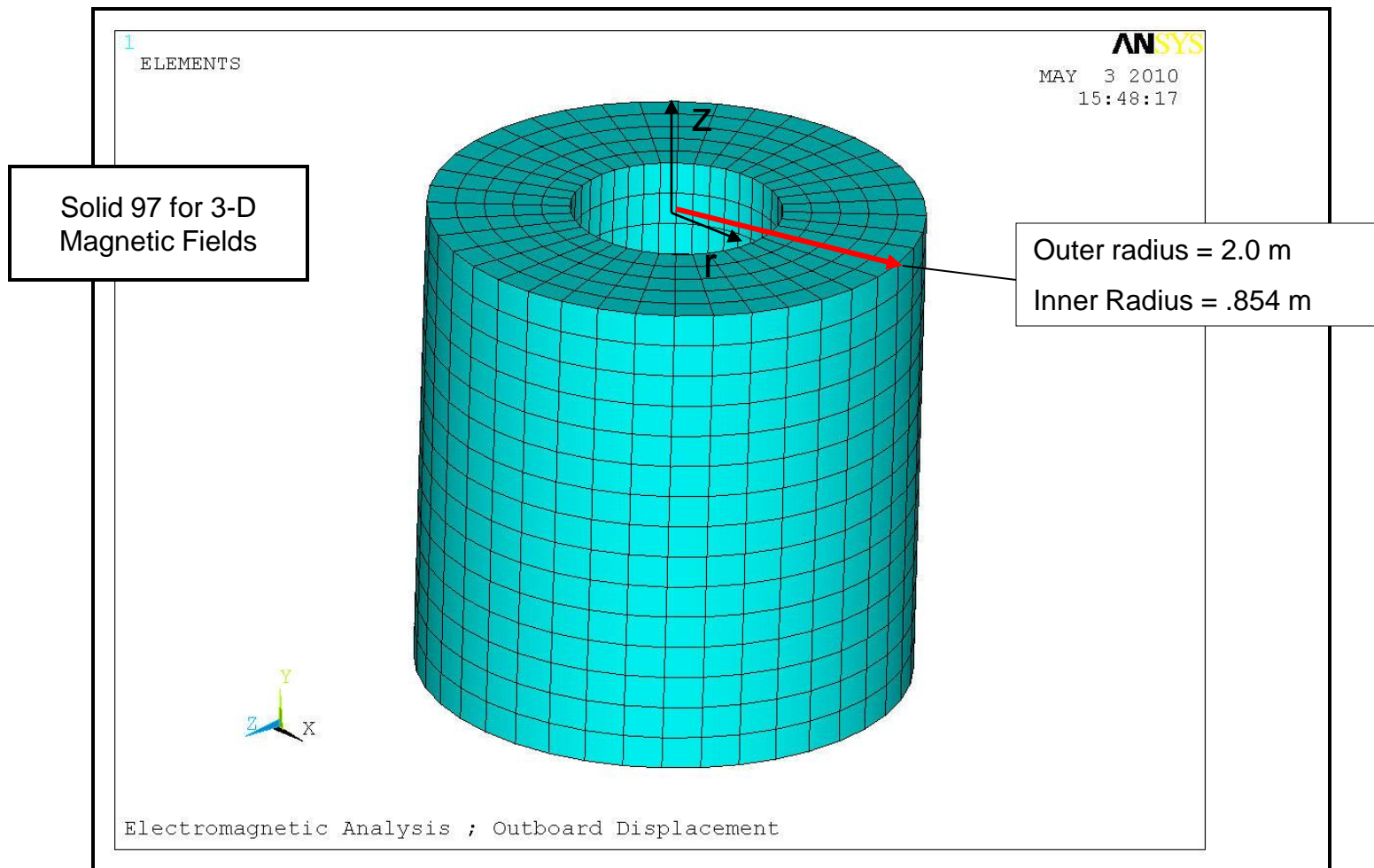

A simplified model of the Reactor space as a cylinder for comparison of the field calculations using the Electromagnetic Script

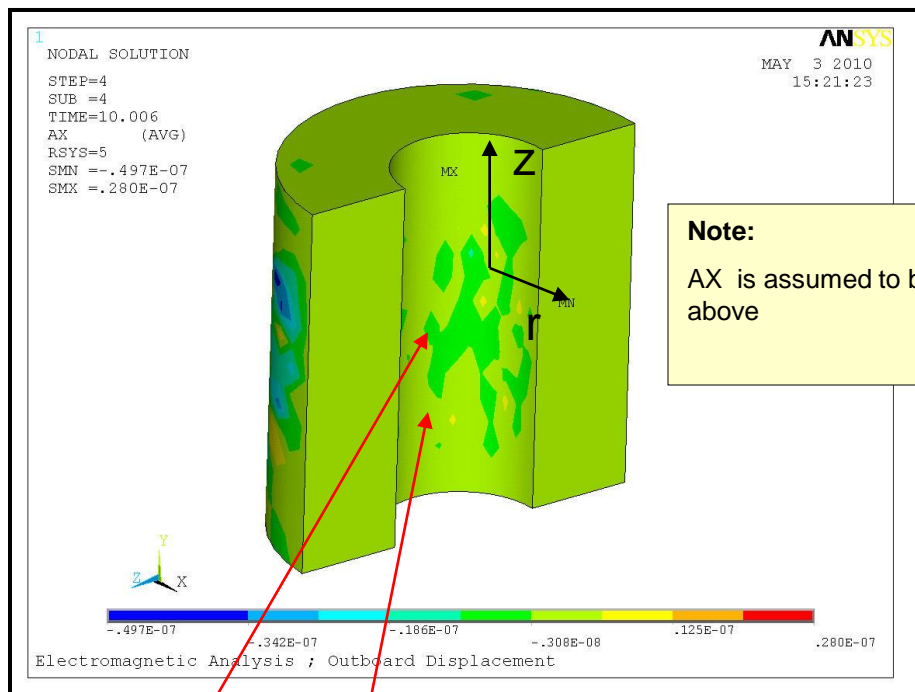

Note:
 AX is assumed to be zero in the ANSYS command script shown above

$$B_x = \nabla X A_r = \frac{1}{r} \frac{\partial A_z}{\partial \theta} - \frac{\partial A_\theta}{\partial z} = -\frac{\partial A_\theta}{\partial z} \quad \text{since : } A_z \neq f(\theta) ; \text{ for symmetric profiles}$$

$$B_\theta = \nabla X A_\theta = \frac{\partial A_r}{\partial z} - \frac{\partial A_z}{\partial r} = -\frac{\partial A_z}{\partial r} \quad \text{since : } A_r \neq f(z) ; \text{ for symmetric profiles}$$

$$B_z = \nabla X A_z = \frac{1}{r} \frac{\partial (r A_\theta)}{\partial r} - \frac{1}{r} \frac{\partial A_r}{\partial \theta} = \frac{1}{r} \frac{\partial (r A_\theta)}{\partial r} \quad \text{since : } A_r \neq f(\theta) \text{ for symmetric profiles}$$

A_θ from Opera program

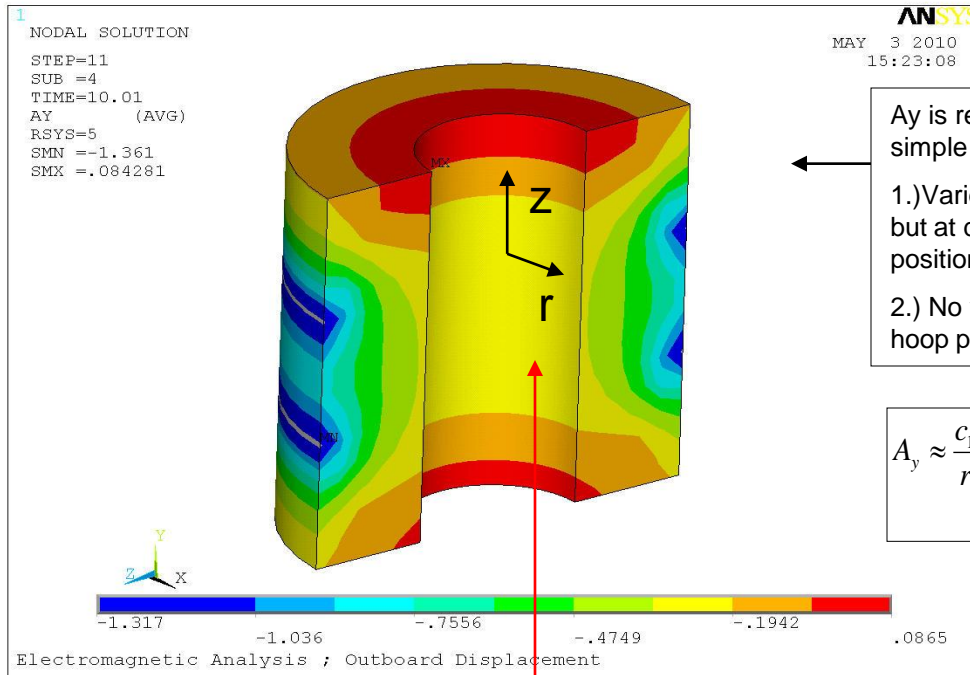

Ay is read in directly from **Opera** and is not a simple function of 1/r

- 1.) Varies as an inverse function of radius at but at different rates of change at different positions along Z axis
- 2.) No variation at any fixed coordinate as hoop position changes.

$$A_y \approx \frac{c_1}{r} - f(1/r, z) \quad f(1/r, z) \approx -0.2 \quad \text{if } z=0$$

$$B_x = \nabla \times A_r = \frac{1}{r} \frac{\partial A_z}{\partial \theta} - \frac{\partial A_\theta}{\partial z} = -\frac{\partial A_\theta}{\partial z} \quad \text{since } : A_z \neq f(\theta) ; \text{ for symmetric profiles}$$

$$B_\theta = \nabla \times A_\theta = \frac{\partial A_r}{\partial z} - \frac{\partial A_z}{\partial r} = -\frac{\partial A_z}{\partial r} \quad \text{since } : A_r \neq f(z) ; \text{ for symmetric profiles}$$

$$B_z = \nabla \times A_z = \frac{1}{r} \frac{\partial (r A_\theta)}{\partial r} - \frac{1}{r} \frac{\partial A_r}{\partial \theta} = \frac{1}{r} \frac{\partial (r A_\theta)}{\partial r} \quad \text{since } : A_r \neq f(\theta) \text{ for symmetric profiles}$$

A_θ from Opera program

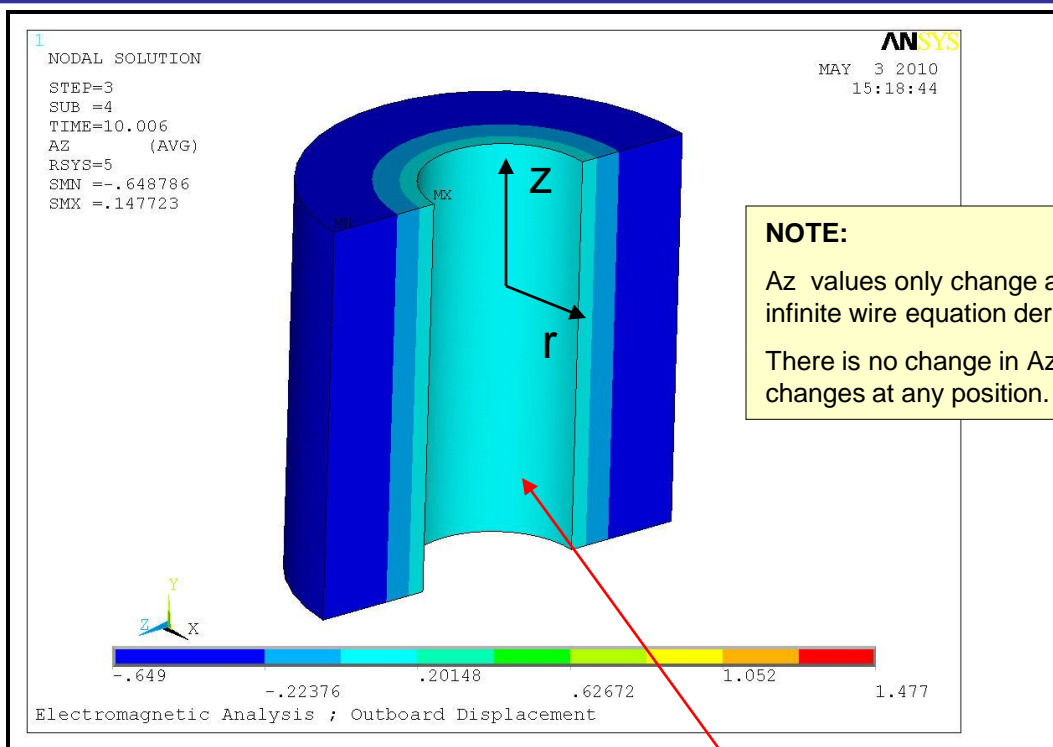

NOTE:

Az values only change as a function of radius from the infinite wire equation derived above.

There is no change in Az as the hoop coordinate changes at any position.

$$B_x = \nabla X A_r = \frac{1}{r} \frac{\partial A_z}{\partial \theta} - \frac{\partial A_\theta}{\partial z} = -\frac{\partial A_\theta}{\partial z} \quad \text{since : } A_z \neq f(\theta) \text{ ; for symmetric profiles}$$

$$B_\theta = \nabla X A_\theta = \frac{\partial A_r}{\partial z} - \frac{\partial A_z}{\partial r} = -\frac{\partial A_z}{\partial r} \quad \text{since : } A_r \neq f(z) \text{ ; for symmetric profiles}$$

$$B_z = \nabla X A_z = \frac{1}{r} \frac{\partial (r A_\theta)}{\partial r} - \frac{1}{r} \frac{\partial A_r}{\partial \theta} = \frac{1}{r} \frac{\partial (r A_\theta)}{\partial r} \quad \text{since : } A_r \neq f(\theta) \text{ for symmetric profiles}$$

A_θ from Opera program

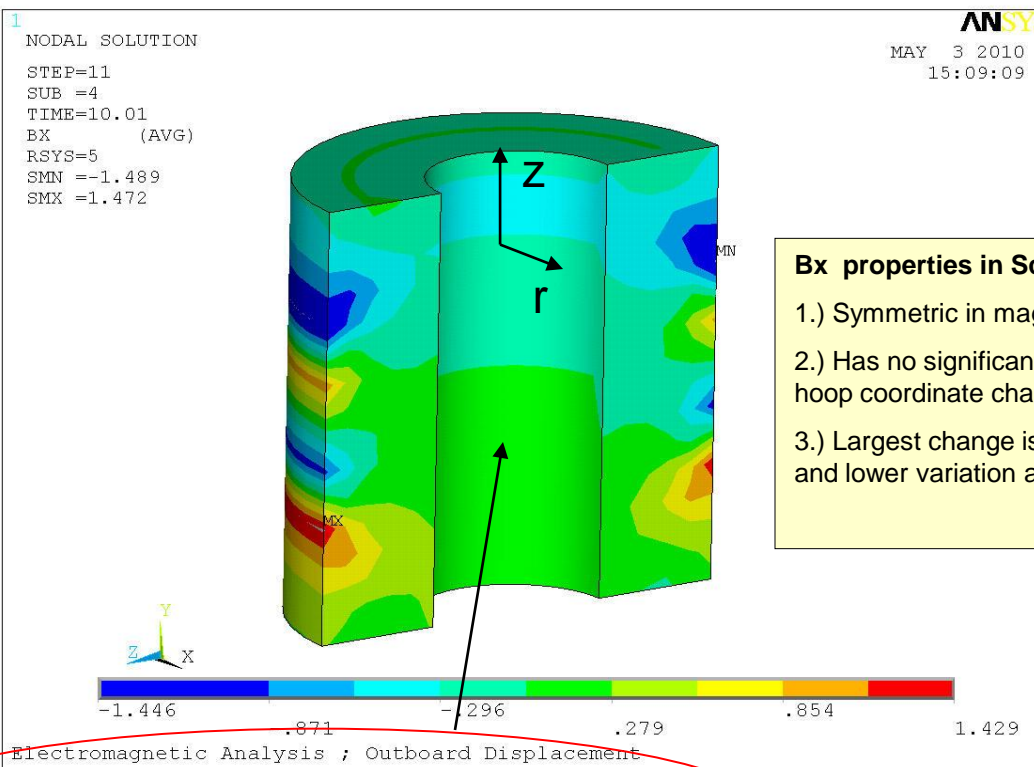

- Bx properties in Script:**
- 1.) Symmetric in magnitude about the Z=0 plane.
 - 2.) Has no significant change at any fixed position as hoop coordinate changes.
 - 3.) Largest change is a function of Z at outer diameter and lower variation at inner diameter.

$$B_x = \nabla X A_r = \frac{1}{r} \frac{\partial A_z}{\partial \theta} - \frac{\partial A_\theta}{\partial z} = -\frac{\partial A_\theta}{\partial z} \text{ since : } A_z \neq f(\theta) \text{ ; for symmetric profiles}$$

$$B_\theta = \nabla X A_\theta = \frac{\partial A_r}{\partial z} - \frac{\partial A_z}{\partial r} = -\frac{\partial A_z}{\partial r} \text{ since : } A_r \neq f(z) \text{ ; for symmetric profiles}$$

$$B_z = \nabla X A_z = \frac{1}{r} \frac{\partial (r A_\theta)}{\partial r} - \frac{1}{r} \frac{\partial A_r}{\partial \theta} = \frac{1}{r} \frac{\partial (r A_\theta)}{\partial r} \text{ since : } A_r \neq f(\theta) \text{ for symmetric profiles}$$

A_θ from Opera program

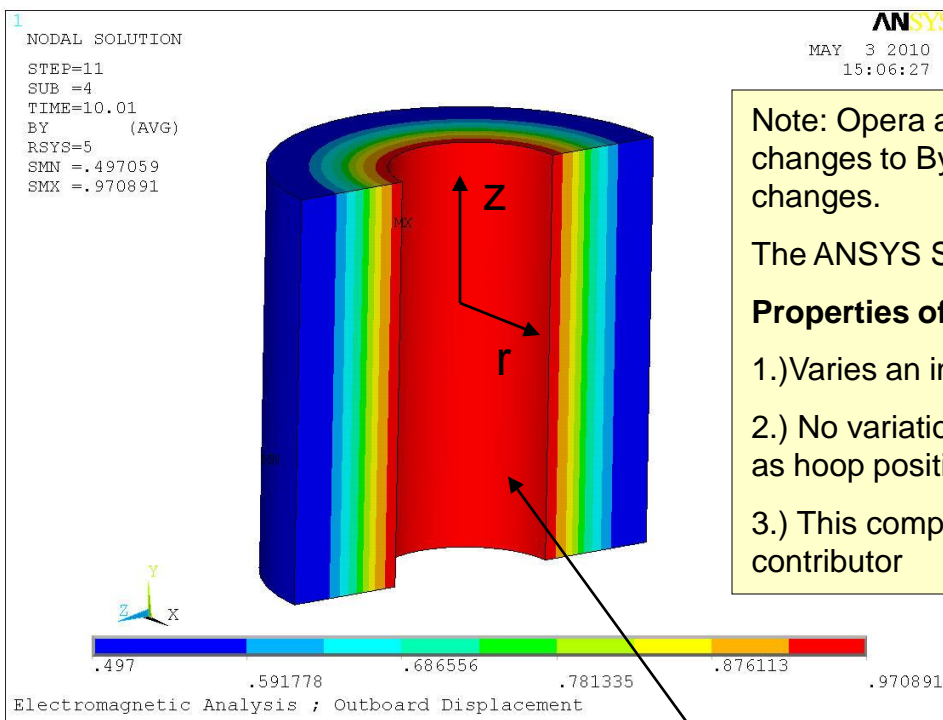

Note: Opera assumes that there are no changes to By as the hoop coordinate changes.

The ANSYS Script applies this contour

Properties of BY in Script:

- 1.)Varies an inverse function of radius
- 2.) No variation at any fixed coordinate as hoop position changes.
- 3.) This component is the largest contributor

$$B_x = \nabla X A_r = \frac{1}{r} \frac{\partial A_z}{\partial \theta} - \frac{\partial A_\theta}{\partial z} = -\frac{\partial A_\theta}{\partial z} \quad \text{since } : A_z \neq f(\theta) ; \text{ for symmetric profiles}$$

$$B_\theta = \nabla X A_\theta = \frac{\partial A_r}{\partial z} - \frac{\partial A_z}{\partial r} = -\frac{\partial A_z}{\partial r} \quad \text{since } : A_r \neq f(z) ; \text{ for symmetric profiles}$$

$$B_z = \nabla X A_z = \frac{1}{r} \frac{\partial (r A_\theta)}{\partial r} - \frac{1}{r} \frac{\partial A_r}{\partial \theta} = \frac{1}{r} \frac{\partial (r A_\theta)}{\partial r} \quad \text{since } : A_r \neq f(\theta) \text{ for symmetric profiles}$$

A_θ from Opera program

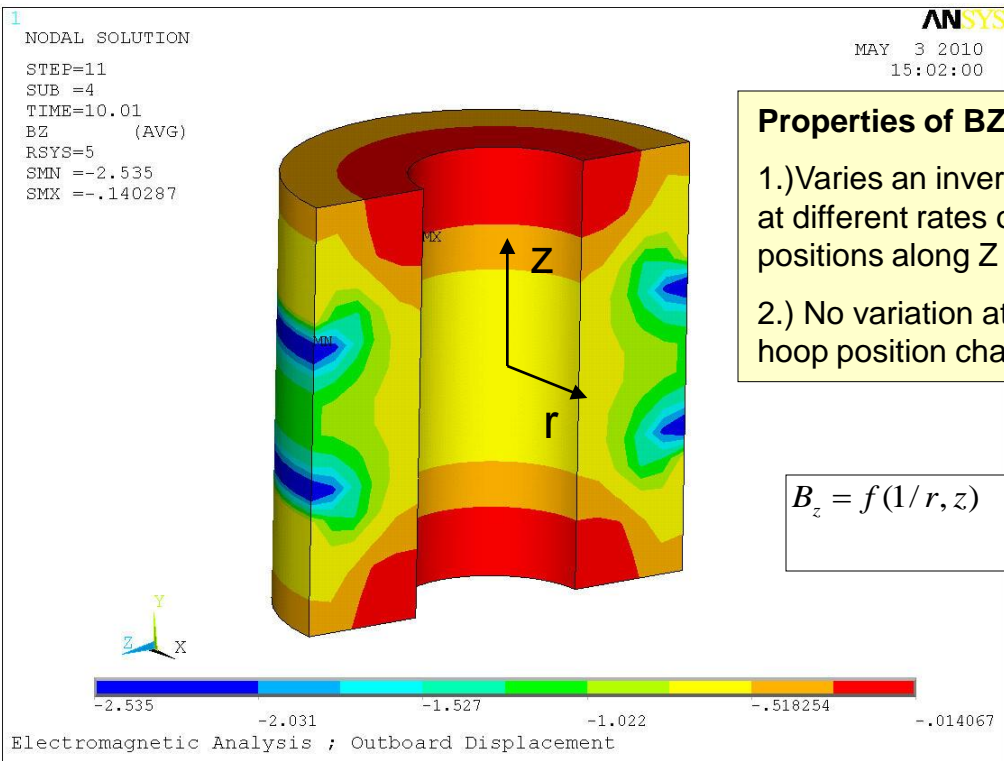

Properties of BZ in Script:

- 1.) Varies an inverse function of radius at but at different rates of change at different positions along Z axis
- 2.) No variation at any fixed coordinate as hoop position changes.

$$B_z = f(1/r, z) \quad f(1/r, z) \approx -.518 \quad \text{if } z = 0$$

$$B_x = \nabla X A_r = \frac{1}{r} \frac{\partial A_z}{\partial \theta} - \frac{\partial A_\theta}{\partial z} = -\frac{\partial A_\theta}{\partial z} \quad \text{since : } A_z \neq f(\theta); \text{ for symmetric profiles}$$

$$B_\theta = \nabla X A_\theta = \frac{\partial A_r}{\partial z} - \frac{\partial A_z}{\partial r} = -\frac{\partial A_z}{\partial r} \quad \text{since : } A_r \neq f(z); \text{ for symmetric profiles}$$

$$B_z = \nabla X A_z = \frac{1}{r} \frac{\partial (r A_\theta)}{\partial r} - \frac{1}{r} \frac{\partial A_r}{\partial \theta} = \frac{1}{r} \frac{\partial (r A_\theta)}{\partial r} \quad \text{since : } A_r \neq f(\theta) \text{ for symmetric profiles}$$

A_θ from Opera program

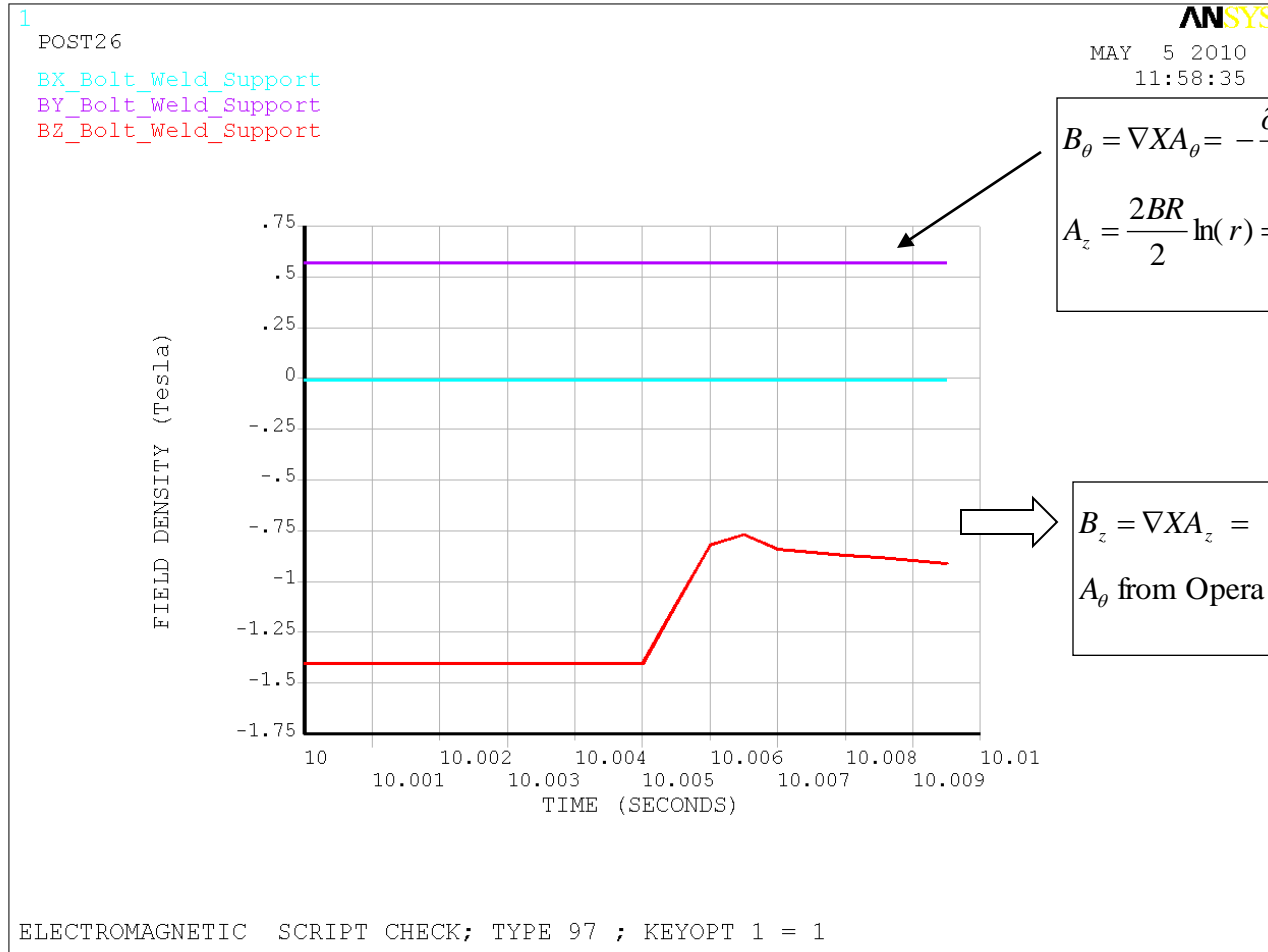

The field from the Ideal Cylinder shows Bz is the largest contributor
 By from the infinite wire has a very small and constant value

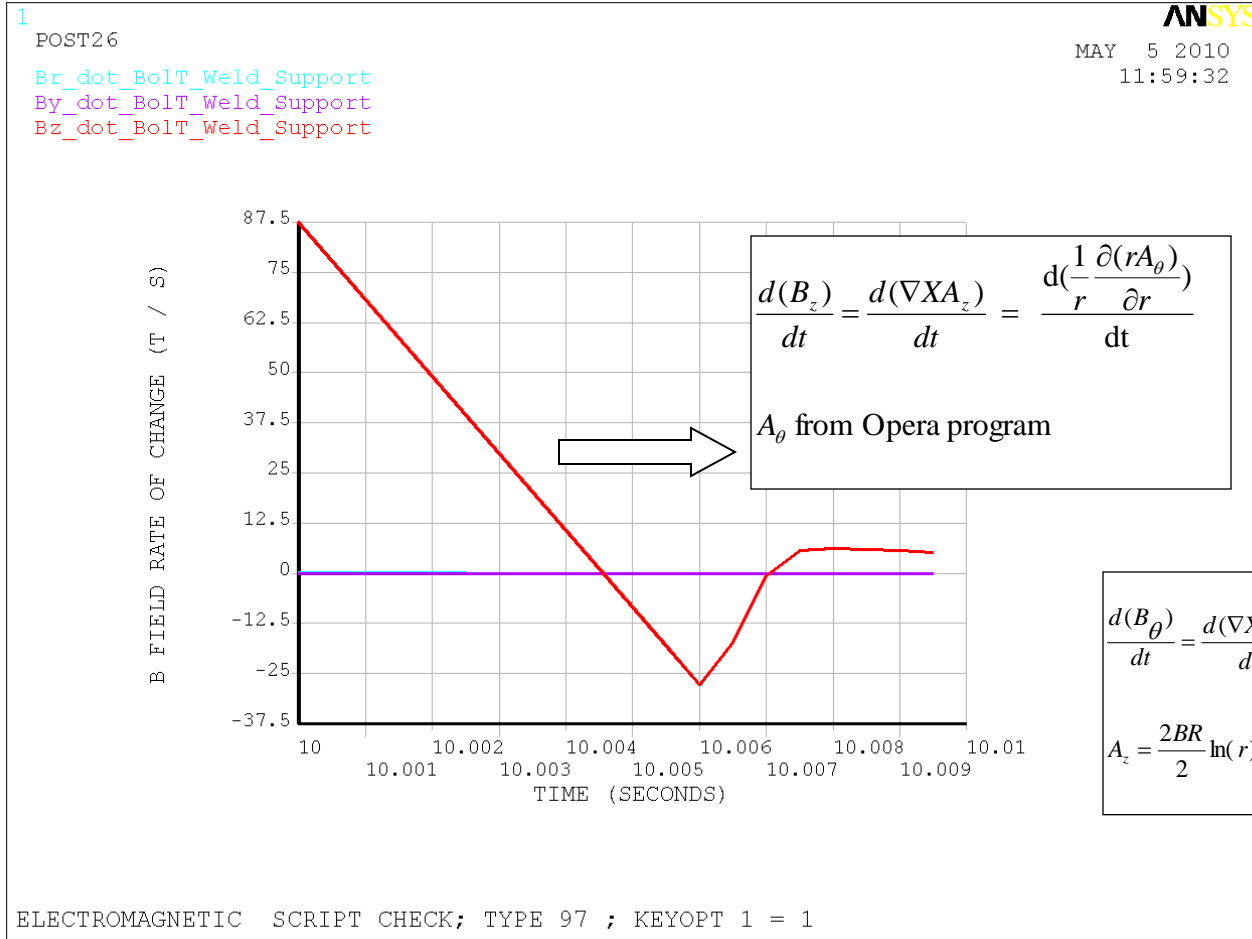

The Flux rate (Bdot) from the Ideal Cylinder shows Bz dot is the largest contributor
 By from the infinite wire has a very small relative impact

Demonstrate that the Applied Electromagnetic Loads Applied in the Armor Analysis is Conservative with the applied script.

- Compare the electromagnetic B fields and rates of change of B fields applied by using the ANSYS script to the values provided in the OPERA program at several discrete locations in the Neutral Beam Armor analysis above.
- Demonstrate how the resulting contour plots of these equations for Vector Potential and B Field did not completely match the intended assumptions in the Neutral Beam Armor analysis.
- Show how the applied loads in this ANSYS electromagnetic analysis are very conservative in comparison to the OPERA calculated analysis.
- Show what corrections were made to the electromagnetic script to reduce the conservatism applied in the script and to allow the OPERA electromagnetic data to match the ANSYS data.
- Show a test case of the Neutral Beam Armor with the corrections and demonstrate that a much better match in the Opera to ANSYS data had been obtained.

B FIELD COMPARISON

TIME	B X	B X	B X	B Y	B Y	B Y	B Z	B Z	B Z
	Bolt Weld	Armor Plate	Armor Plate	Bolt Weld	Armor Plate	Armor Plate	Bolt Weld	Armor Plate	Armor Plate
10	-0.254524	-0.257837	-0.441618	0.592054	0.606551	0.594702	-1.40825	-1.38778	-1.48148
10.005	-0.254524	-0.257837	-0.441618	0.592054	0.606551	0.594702	-1.40825	-1.38778	-1.48148
10.006	-0.204063	-0.191579	-0.338777	0.592153	0.606672	0.594863	-1.03435	-1.0366	-1.23867
10.006	-0.151308	-0.123944	-0.236554	0.592255	0.606796	0.595024	-0.665195	-0.689504	-0.989148
10.007	-0.136419	-0.107519	-0.214723	0.592282	0.606828	0.595058	-0.604015	-0.631578	-0.934217
10.007	-0.141459	-0.11699	-0.230224	0.592269	0.606815	0.595034	-0.698978	-0.720783	-0.987923
10.008	-0.137178	-0.113564	-0.224289	0.592275	0.606825	0.595043	-0.720506	-0.741341	-0.999644
10.008	-0.133354	-0.110439	-0.218653	0.59228	0.606834	0.595052	-0.741778	-0.761762	-1.01292
10.008	-0.129929	-0.107591	-0.21331	0.592284	0.606842	0.59506	-0.762448	-0.781686	-1.02701
10.009	-0.126866	-0.105006	-0.208308	0.592288	0.60685	0.595068	-0.782342	-0.800923	-1.04141
10.01	-0.124124	-0.102667	-0.203665	0.592292	0.606858	0.595075	-0.801397	-0.819396	-1.05582

Highlighted Data Graphed & Compared to OPERA next Slides

NODE	R	Y	Z	
29680	1.5776	-151.95	-0.14623	BOLT WELD
38971	1.5388	-153.70	-0.17847	PLATE
103492	1.5703	-171.92	-0.39053	PLATE SUPPORT

Three Locations Identified for B OBD Field from ANSYS program
Data shows BZ is the largest contributor during disruptions

OPERA FIELD & FLUX RATE For OBD R. HATCHER 5-3-10 ($r=1.5776$ m $Z=-.014623$ m)

T [s]	Br [T]	Bz [T]	B	dBr/dt	dBz/dt	d B /dt
0.00E+00	-0.0260	0.5472	0.5478			
5.00E-03	-0.0260	0.5472	0.5478	0.00	0.00	0.00
5.50E-03	-0.0241	0.5374	0.5379	3.89	-19.74	-19.89
6.00E-03	-0.0212	0.5255	0.5259	5.63	-23.79	-24.00
6.50E-03	-0.0177	0.5124	0.5127	7.00	-26.05	-26.29
7.00E-03	-0.0135	0.4985	0.4987	8.40	-27.92	-28.17
7.50E-03	-0.0108	0.4942	0.4944	5.41	-8.46	-8.59
8.00E-03	-0.0084	0.4914	0.4915	4.98	-5.68	-5.77
8.50E-03	-0.0060	0.4895	0.4895	4.69	-3.88	-3.95
9.00E-03	-0.0038	0.4881	0.4882	4.47	-2.64	-2.68
9.50E-03	-0.0016	0.4873	0.4873	4.28	-1.73	-1.76
1.00E-02	0.0004	0.4868	0.4868	4.12	-1.05	-1.06

ANSYS FLUX RATE FROM OUTBOARD 4-30-10

ANSYS DERIVATIVE RESULTS				
TIME	20 DERI Br dot B	21 DERI BY dot B	22 DERI BZ dot B	
0		-22.9381	-3.59E-02	47.5091
0.005		91.747	0.179558	679.825
0.006		103.216	0.201101	743.056
0.0065		67.6443	0.129268	430.333
0.007		9.84905	1.42E-02	-33.7834
0.0075		-0.759602	-7.01E-03	-116.492
0.008		8.10563	1.07E-02	-42.7997
0.0085		7.24953	9.41E-03	-41.9419
0.009		6.48747	8.31E-03	-40.5637
0.0095		5.8049	7.35E-03	-38.9491
0.01		5.12233	6.40E-03	-37.3344

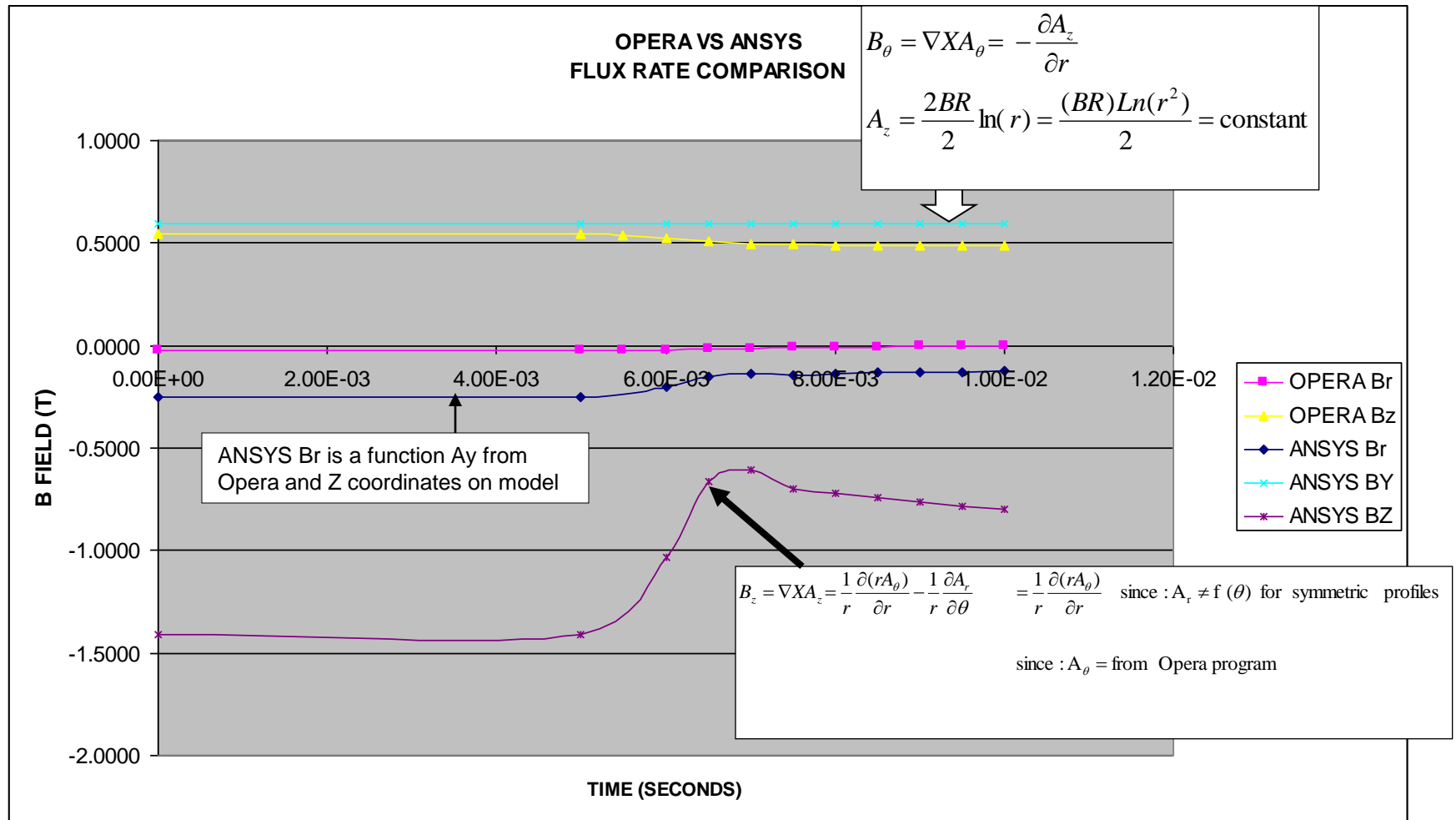

ANSYS & OPERA Provide Similar Br Fields
 By field is added field from the infinite wire assumption
Bz is the largest component during disruption – based on Opera Ay

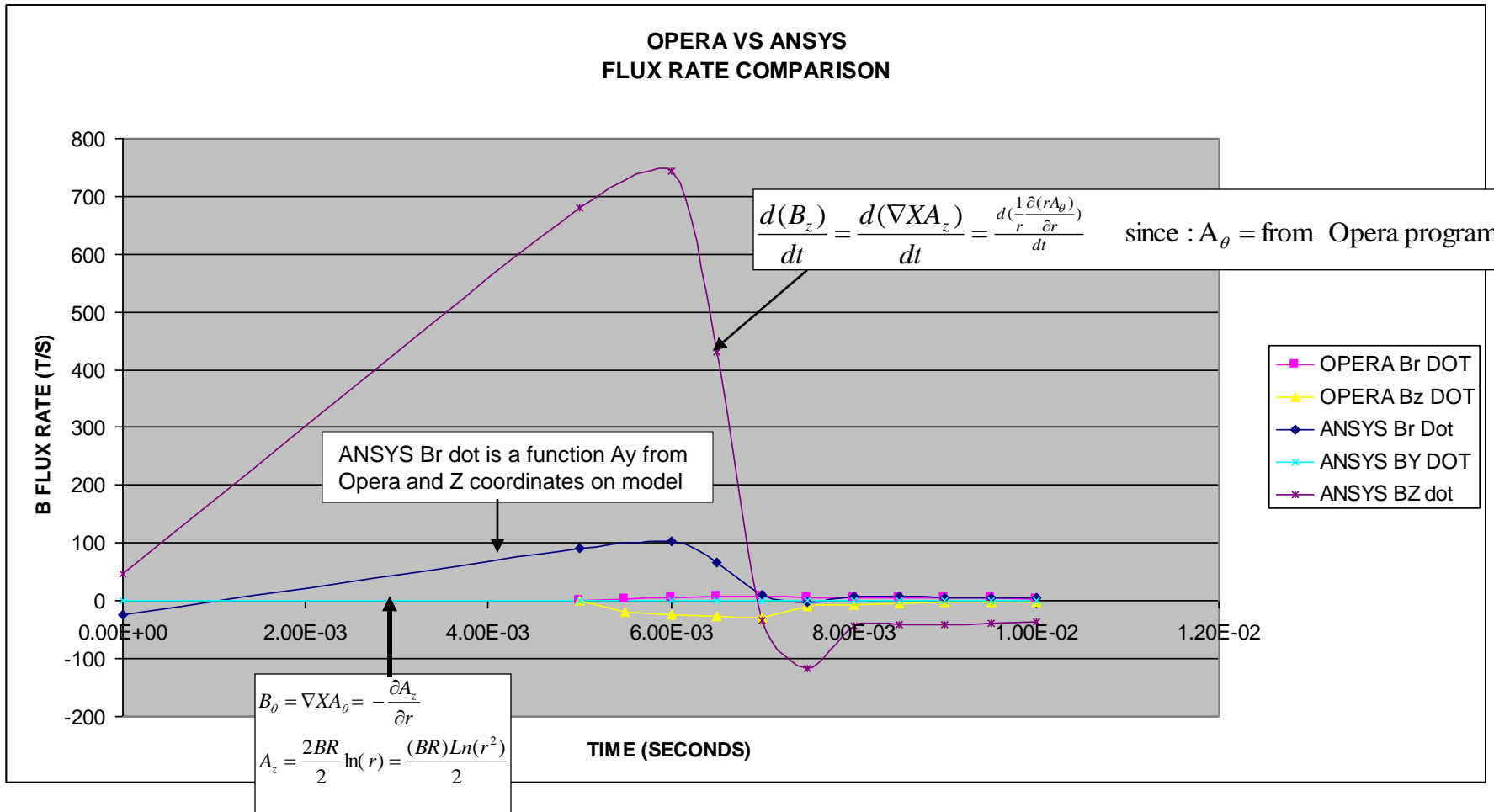

ANSYS disruption is primarily controlled by Bz dot which is derived from the A_y input from Opera – The relative contribution of B_y is small
This shows that the ANSYS electromagnetic loads were very conservative

```
ESYSTEM-MODIFY.txt - Notepad
File Edit Format View Help
***** THIS SCRIPT WILL:
***** AUTOMATICALLY INSERT THE REQUIRED CYLINDRICAL ELEMENT COORDINATE SYSTEM
***** THIS ESYS WILL PARALLEL THE DESIGN CSYS 5 USED IN DESIGN
***** SELECT EACH ELEMENT TYPE IN YOUR PREP7 DATA BASE, DETERMINE THE ATTRIBUTES YOU DEFINED
PREVIOUSLY
***** MODIFY EACH OF YOUR ELEMENT TYPES WITH THE NEW COORDINATE SYSTEM
***** THIS ESYS IS REQUIRED TO ASSURE YOUR ELECTROMAGNETIC LOADS ARE CALCULATED AND APPLIED
***** IN THE PROPER DIRECTION - WITHOUT THIS THE Bz and BY FIELDS ARE SWITCHED

/PREP7
ALLS

*get,MAXKP,KP,,NUM,MAX

*get,MAXCS,CDSY,,NUM,max

csys,5

K,MAXKP+1
K,MAXKP+2,-5,0
K,MAXKP+3,-5,90

CSKP,MAXCS+1,1,MAXKP+1,MAXKP+2,MAXKP+3

*get,ESYS_MAX,ETYP,0,NUM,MAX

*do,1,1,ESYS_MAX

allsel

ESEL,S,TYPE,,I

*GET,E_SEL,ELEM,0,COUNT

*IF,E_SEL,GT,0,THEN,
ENUMBER=ELNEXT(1)

*get,TYPE_ETYPE,ELEM,ENUMBER,ATTR,TYPE
*get,MAT_ETYPE,ELEM,ENUMBER,ATTR,MAT
*get,REAL_ETYPE,ELEM,ENUMBER,ATTR,REAL

TYPE,TYPE_ETYPE $MAT,MAT_ETYPE
REAL,REAL_ETYPE $ESYS,MAXCS+1

EMOD,ALL

*ELSE

*CYCLE

*ENDIF

*enddo

ALLSEL
```

This Script Was Used on the ANSYS database to Insert and Rotate the Element coordinate system – This was only necessary to assure Bz dot and By dot graphical comparisons match the data provided in OPERA. Nodal stresses and Nodal Loads are essentially the same with or without this change

INCLUDE ESYSTEM

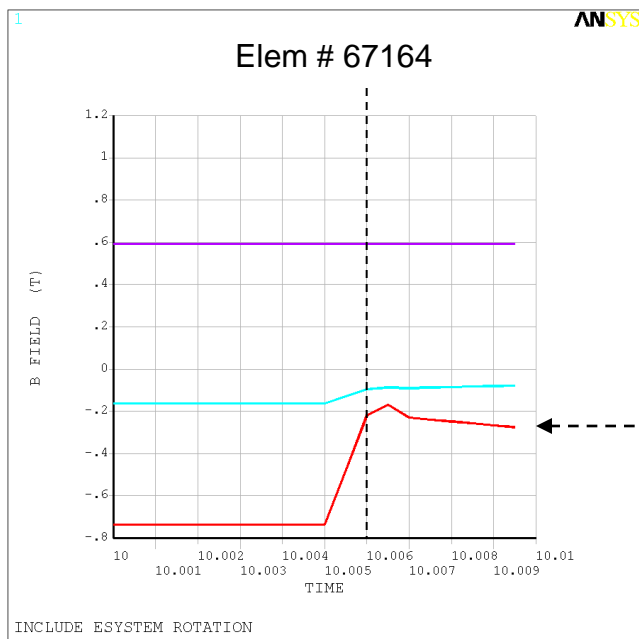

EXCLUDE SYSTEM

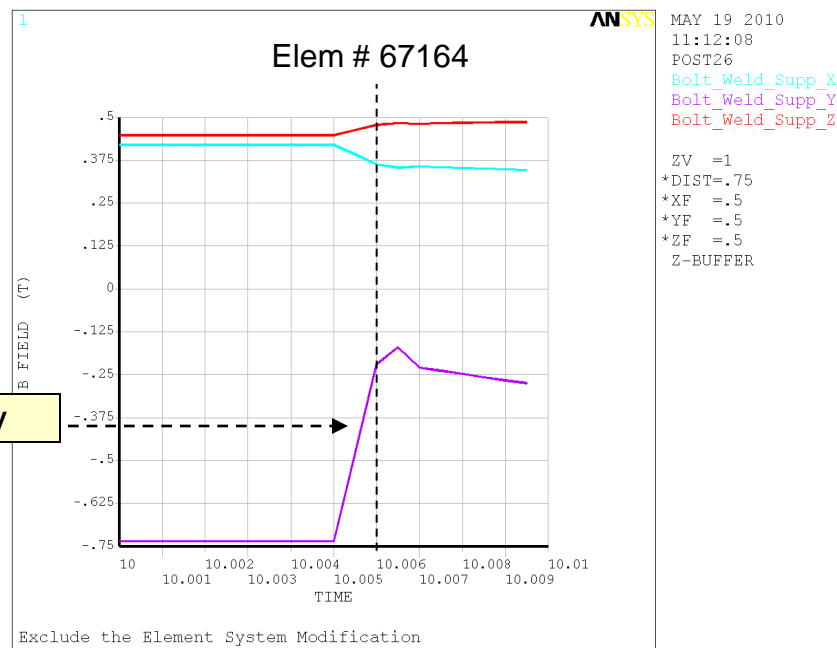

Bz vs By

$$B_z = \nabla X A_z = \frac{1}{r} \frac{\partial(rA_\theta)}{\partial r}$$

A_θ from Opera program

The primary contributor (Bz) to the Flux Field is switched with By Field History

INCLUDE ESYSTEM

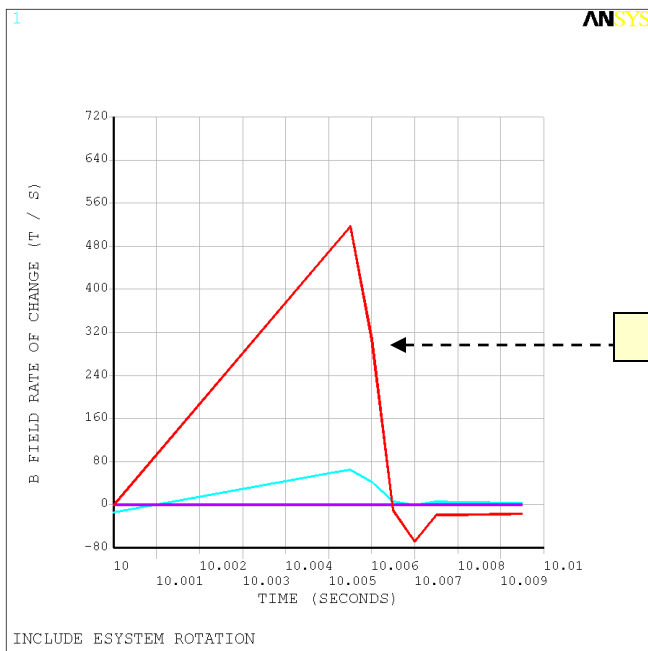

EXCLUDE SYSTEM

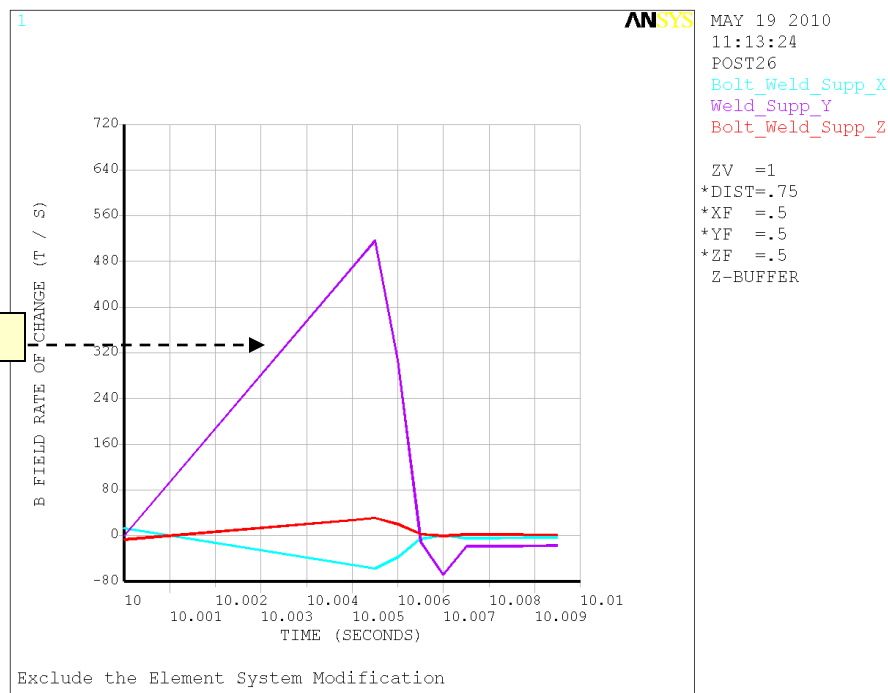

Bz vs By

The primary contributor (Bz) to the Flux Field is switched with By Field History

A = Vector Potential in Opera

B = Electromagnetic Field

OPERA - program assumes :

$$A^* = rA$$

ANSYS script did not previously incorporate the additional radius term in the OPERA data

$$\begin{aligned} B^* &= \nabla X A^* = \nabla X (rA) = r \nabla X A + A X \nabla r \\ &= rB - AXr \\ &= rB - Az \\ &= r[B_r r + B_z z] - Az \end{aligned}$$

To reduce the conservatism in the magnitude of the previous Bz data and to get closer correspondence to the ANSYS data it was determined that the ANSYS script would need to have all applied vector potential data values provided by OPERA be divided by the radius at of each point.

The next slide applies this correction and demonstrates the improvement.

APPENDIX 3

- Demonstrate for the VDE disruption file that applying the changes described results in a an excellent match in the B field and flux rate data between ANSYS and OPERA.
 - Switch the element coordinate system with Z & Y to assure the resulting fields and current densities are aligned properly.
 - Divide all OPERA program Vector Potentials by the radius at each location.
 - Recommended by R. Hatcher 5-12-10

OPERA / ANSYS

DATA INCLUDES:

- 1.) Infinite Wire Assumption
- 2.) Rotated Element Coordinate System
 - a.) B_z major contributor to flux Rate
 - b.) B_y is almost no contribution to flux rate
- 3.) Divided out radius from all points for OPERA data

OPERA Data
Divided by radius

```

/solu
antype,trans,new
trnopt,full
SOLCONTROL,ON
timint,off
outres,all,last
time,10
autots,on
deltim,10,10,10
kbc,0
*do,i,1,nmax
z=nz(i)
x=nx(i)
d,i,ay,vect0(x,z)/x
d,i,az,-0.5*BR*log(x*x)
*enddo
d,all,ax,0.
SOLVE

timint,on
time,10.005
autots,on
deltim,.001,.0005,.002
kbc,0
*do,i,1,nmax
z=nz(i)
x=nx(i)
d,i,ay,vect5(x,z)/x
d,i,az,-0.5*BR*log(x*x)
*enddo
d,all,ax,0.
SOLVE
    
```

Infinite Wire Included

$$B_z = \nabla X A_z = \frac{1}{r} \frac{\partial(rA_\theta)}{\partial r}$$

A_θ from Opera program

1

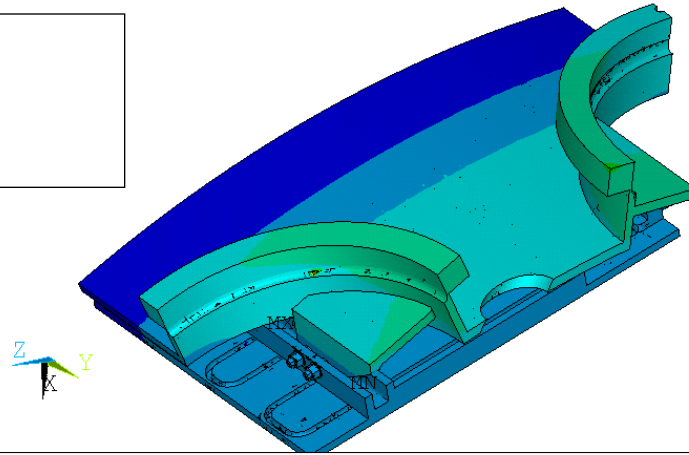

ANSYS

MAY 13 2010
09:20:39
NODAL SOLUTION
STEP=5
SUB =4
TIME=10.007
BZ (AVG)
RSYS=5
SMN =-7.287
SMX =5.269

XV =-.45151
YV =.659225
ZV =.601299
*DIST=.335162
*XF =-1.533
*YF =-.250928
*ZF =.493506
A-ZS=-125.643
Z-BUFFER

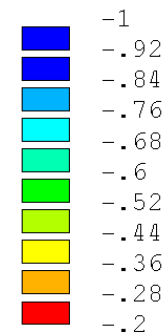

2

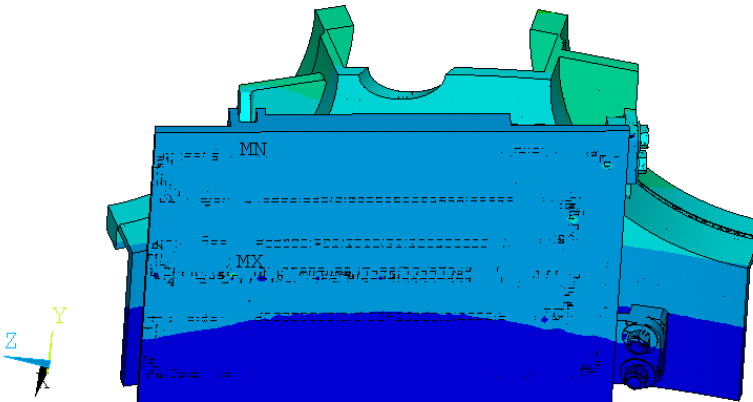

NEUTRAL BEAM ARMOR - VECTOR POTENTIAL

The primary contributor (B_z) to the Flux Field is calculated from
The Curl of the input Vector Potential provided by the Opera Program

B FIELD COMPARISON

TIME	B X	B X	B X	B Y	B Y	B Y	B Z	B Z	B Z
	Bolt Weld	Armor Plate	Armor Plate	Bolt Weld	Armor Plate	Armor Plate	Bolt Weld	Armor Plate	Armor Plate
10	0.172703	-0.178575	-0.316111	-0.592204	0.606696	0.5949	0.817814	-0.835289	-0.835591
0.005	0.172703	-0.178575	-0.316111	-0.592204	0.606696	0.5949	0.817814	-0.835289	-0.835591
0.0055	0.170925	-0.176174	-0.31347	-0.592207	0.606701	0.594904	0.810947	-0.828747	-0.833343
0.006	0.165934	-0.169542	-0.305977	-0.592215	0.606717	0.594916	0.794084	-0.812757	-0.828621
0.0065	0.158491	-0.159824	-0.294666	-0.592227	0.606739	0.594934	0.772246	-0.792153	-0.82358
0.007	0.149688	-0.148549	-0.281164	-0.592241	0.606766	0.594954	0.750035	-0.771304	-0.819558
0.0075	0.140845	-0.137492	-0.267508	-0.592256	0.606793	0.594976	0.731758	-0.754265	-0.817445
0.008	0.132304	-0.127047	-0.25432	-0.592269	0.606818	0.594996	0.716965	-0.740538	-0.8164
0.0085	0.123422	-0.116302	-0.24071	-0.592283	0.606844	0.595017	0.702441	-0.727045	-0.815186
0.009	0.114198	-0.105246	-0.226672	-0.592297	0.606871	0.595039	0.688184	-0.713793	-0.813908
0.0095	0.10464	-9.39E-02	-0.212213	-0.592312	0.606899	0.595061	0.674184	-0.700779	-0.812631
0.01	0.0947648	-8.22E-02	-0.197348	-0.592327	0.606928	0.595085	0.660425	-0.687991	-0.81138
0.011	0.0741217	-5.80E-02	-0.166488	-0.592359	0.606988	0.595132	0.633566	-0.663028	-0.808988
0.012	0.0524188	-3.29E-02	-0.134299	-0.592392	0.607051	0.595182	0.607447	-0.638758	-0.806737
0.013	0.0295154	-6.42E-03	-0.100561	-0.592427	0.607117	0.595235	0.580933	-0.6141	-0.804272
0.014	0.0048951	2.19E-02	-6.45E-02	-0.592465	0.607187	0.595291	0.552676	-0.587803	-0.801513
0.015	-0.0184282	4.82E-02	-3.05E-02	-0.5925	0.607254	0.595343	0.532972	-0.569636	-0.801382
0.016	-0.0368807	6.79E-02	-4.15E-03	-0.592527	0.607305	0.595384	0.529467	-0.566721	-0.804708
0.017	-0.050024	8.09E-02	1.37E-02	-0.592546	0.60734	0.595412	0.537766	-0.574778	-0.809102
0.018	-0.0589794	8.88E-02	2.49E-02	-0.592558	0.607363	0.595429	0.551476	-0.587765	-0.812997
0.019	-0.0654101	9.40E-02	3.22E-02	-0.592566	0.607378	0.595441	0.564859	-0.600308	-0.815508
0.02	-0.0713928	9.92E-02	3.89E-02	-0.592575	0.607393	0.595451	0.572616	-0.607467	-0.815991

** ANSYS Br By and BZ values multiplied by -1 to match OPERA sign convention

Highlighted Data Graphed

NODE R Y Z
29680 1.5776 -151.95 -0.14623 BOLT WELD

Three Locations Identified for B Field VDE disruption from ANSYS program
Data shows BZ is the largest contributor during disruptions

OPERA VS ANSYS
FLUX RATE COMPARISON

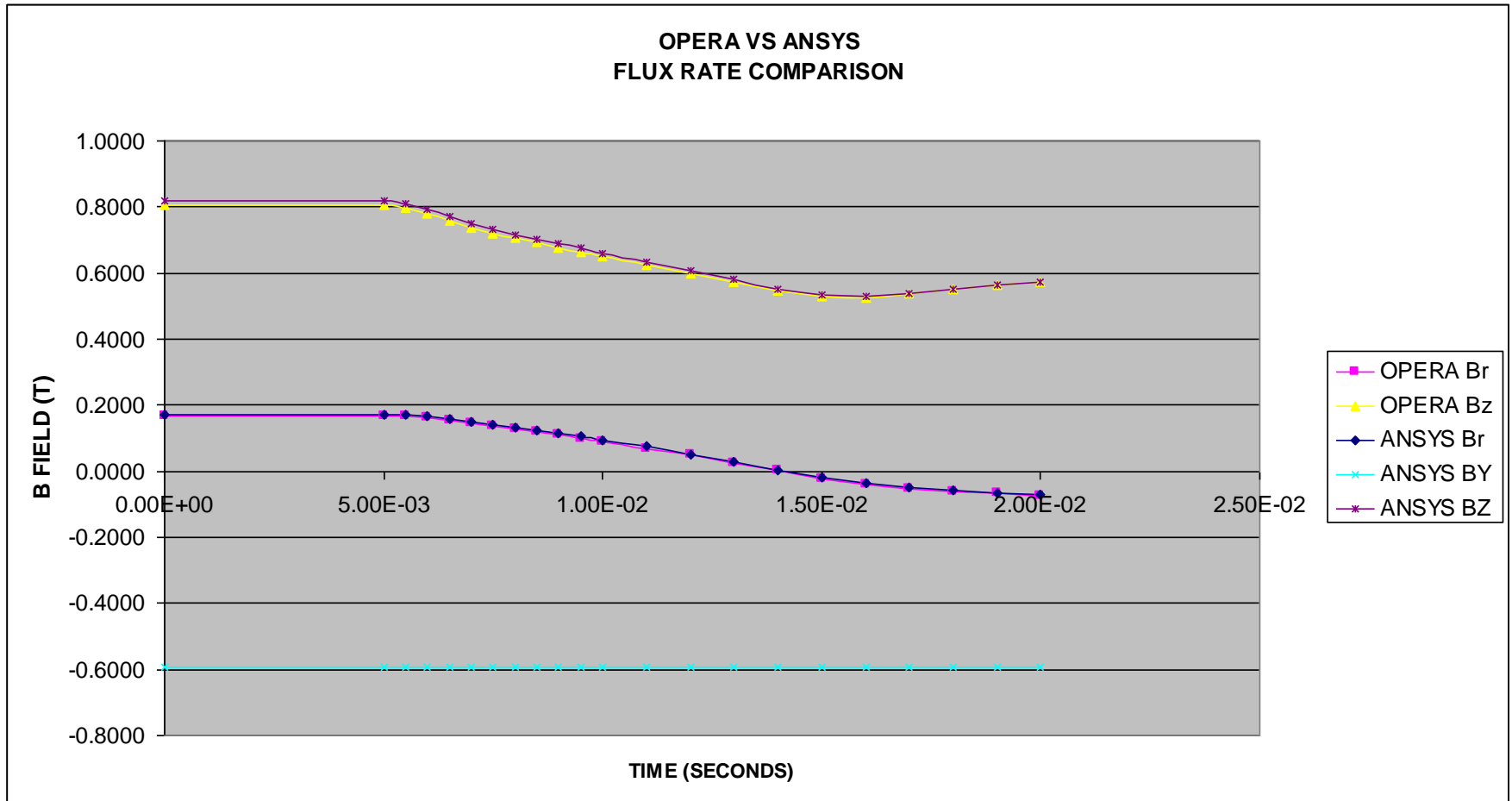

ANSYS & OPERA Provide Almost Identical Br and Bz Fields
ANSYS By field is added field from the infinite wire assumption

VDE DISRUPTION B Dot

ANSYS DERIVATIVE RESULTS				
TIME	20 DERI Br dot B	21 DERI BY dot B	22 DERI BZ dot B	
0	32.139	5.32E-02	99.9658	
0.005	-3.23173	-5.50E-03	-12.485	
0.0055	-6.7688	-1.14E-02	-23.73	
0.006	-12.4344	-2.06E-02	-38.701	
0.0065	-16.2456	-2.65E-02	-44.0492	
0.007	-17.6461	-2.83E-02	-40.4878	
0.0075	-17.3838	-2.74E-02	-33.0695	
0.008	-17.4226	-2.72E-02	-29.317	
0.0085	-18.1061	-2.82E-02	-28.7815	
0.009	-18.7821	-2.92E-02	-28.2576	
0.0095	-19.4336	-3.01E-02	-27.7582	
0.01	-20.0481	-3.09E-02	-27.2974	
0.011	-21.173	-3.25E-02	-26.4889	
0.012	-22.3031	-3.42E-02	-26.3163	
0.013	-23.7618	-3.63E-02	-27.3857	
0.014	-23.9718	-3.64E-02	-23.9807	
0.015	-20.8879	-3.12E-02	-11.6045	
0.016	-15.7979	-2.28E-02	2.39712	
0.017	-11.0494	-1.54E-02	11.0045	
0.018	-7.69309	-1.03E-02	13.5463	
0.019	-6.20671	-8.33E-03	10.5701	
0.02	-4.72032	-6.35E-03	7.59395	

** ANSYS Br , By and BZ values multiplied by -1 to match OPERA sign convention

Weld B dot for Field VDE disruption from ANSYS program
 Data shows BZ is the largest and Br a close second contributor during disruptions
 The BY dot is zero and has no contribution

OPERA FIELD & FLUX RATE For OBD R. HATCHER 5-11-10
($r=1.5776$ m $Z=-.14623$ m)

T [s]	Br [T]	Bz [T]	B	dBr/dt	dBz/dt	d B /dt
0.00E+00	0.0022	0.8063	0.8063			
5.00E-03	0.0022	0.8063	0.8063	0.00	0.00	0.00
5.50E-03	0.0016	0.7980	0.7980	-1.19	-16.46	-16.46
6.00E-03	-0.0002	0.7776	0.7776	-3.62	-40.91	-40.92
6.50E-03	-0.0031	0.7508	0.7508	-5.75	-53.57	-53.56
7.00E-03	-0.0066	0.7233	0.7233	-7.15	-55.05	-55.00
7.50E-03	-0.0104	0.7003	0.7004	-7.58	-45.85	-45.75
8.00E-03	-0.0142	0.6817	0.6818	-7.59	-37.31	-37.17
8.50E-03	-0.0182	0.6635	0.6637	-7.99	-36.41	-36.20
9.00E-03	-0.0224	0.6457	0.6461	-8.42	-35.59	-35.31
9.50E-03	-0.0269	0.6283	0.6288	-8.86	-34.84	-34.47
1.00E-02	-0.0315	0.6112	0.6120	-9.28	-34.15	-33.67
1.10E-02	-0.0414	0.5780	0.5795	-9.89	-33.22	-32.55
1.20E-02	-0.0520	0.5458	0.5483	-10.64	-32.16	-31.17
1.30E-02	-0.0634	0.5133	0.5172	-11.41	-32.49	-31.06
1.40E-02	-0.0758	0.4788	0.4847	-12.39	-34.55	-32.49
1.50E-02	-0.0881	0.4546	0.4631	-12.28	-24.13	-21.64
1.60E-02	-0.0988	0.4506	0.4612	-10.65	-4.09	-1.85
1.70E-02	-0.1073	0.4614	0.4737	-8.56	10.87	12.49
1.80E-02	-0.1141	0.4793	0.4927	-6.75	17.91	18.98
1.90E-02	-0.1195	0.4971	0.5112	-5.48	17.74	18.53
2.00E-02	-0.1246	0.5080	0.5230	-5.01	10.88	11.76

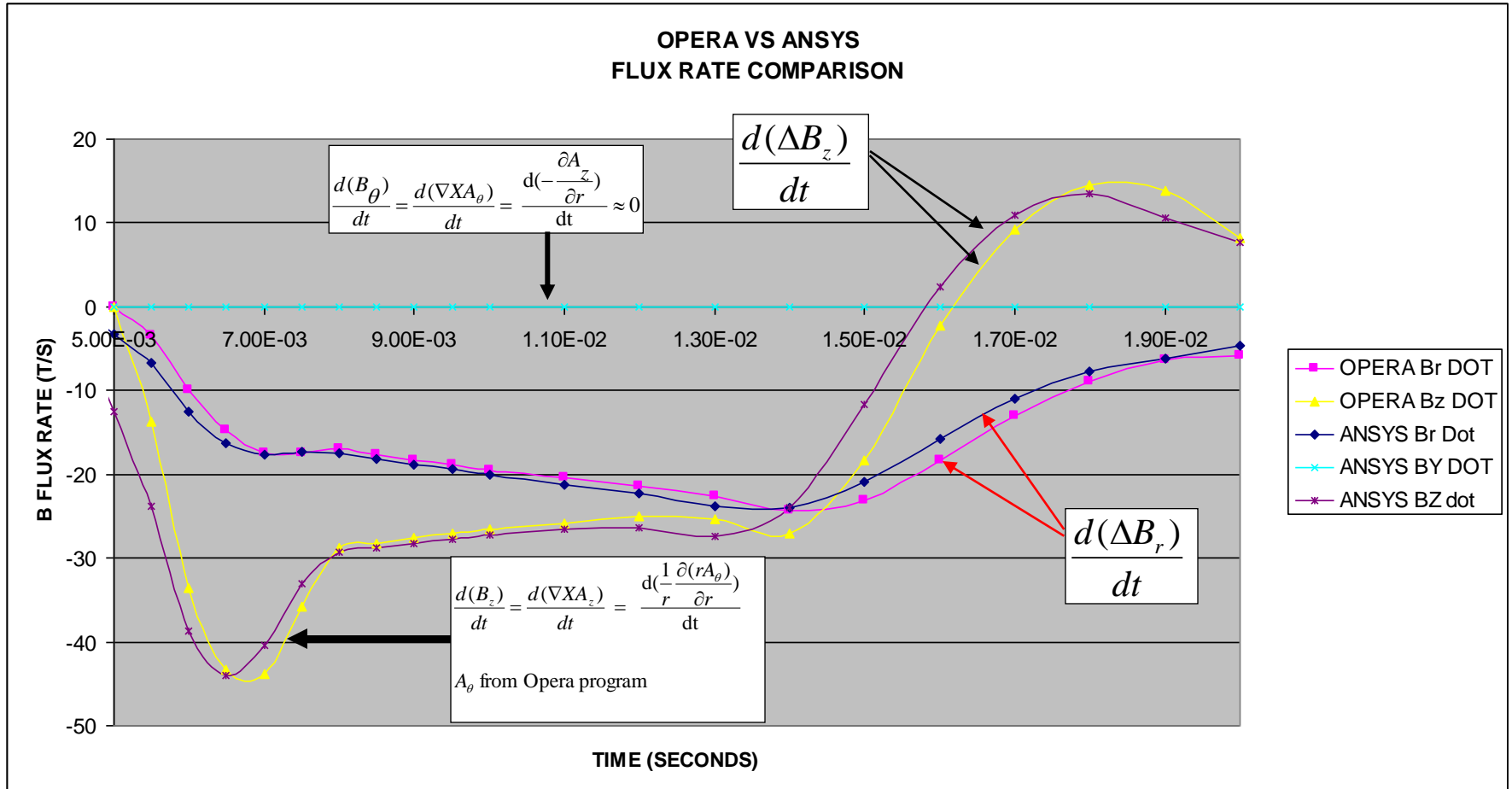

ANSYS and OPERA data are excellent matches for all time points
ANSYS By dot is zero since input as a constant
Bz dot is the largest contributor

CONCLUSIONS

- The Electromagnetic script used for processing the ANSYS models has been checked and evaluated for input and theoretical values.
- The ANSYS Field calculations for Bx is similar to OPERA, however, the ANSYS Bz is significantly different from the OPERA values for the disruption file provided for the OBD disruption.
- The results demonstrated that changes to the script were necessary in order to assure consistency with the OPERA electromagnetic data.
- An APDL script (ESYSTEM-MODIFY) was constructed to include an automatic generation of an element system that corresponds with the cylindrical nodal coordinate system 5. The script selects the users defined element types and modifies each one separately while maintaining the previously define values for Real, Mat, and Type numbers.
 - Each user will need to independently verify that their all of their FE model elements have this element system defined and that each element has been rotated into this system.
- **With the changes to the script we determined for the OPERA field results:**
 - Br are close and differences could be explained with small position differences.
 - Bz results are significantly different due to differences in the theory and perhaps some mistake in the generation of the disruption profiles.
 - ANSYS Bz is calculated based on input of AY from Opera and is the largest rate contributor.
 - OPERA Bz is calculated based on additional coils that we do not model or include in ANSYS
 - ANSYS By is a constant as input from the script (Infinite Wire) Opera does not have a By value
- Without adding the rotated element coordinate system the BY and BZ field values are switched in the result output.

RECOMMENDATIONS

- Previous runs using the in house Electromagnetic script should be re-checked to verify that results are consistent with the new element coordinate system addition.
- The attached APDL script (ESYSTEM-MODIFY) can be used to generate the proper cylindrical coordinate stem and change all of the elements in the model to include this change.
- Consider evaluating the influence of discretization error by investigating Ron Hatchers mesh.
- Given that the B_z and B_z -dot field calculations are significantly different, we need to establish a more robust central data base for cataloging the disruption files.
 - Text Headers should be added to each disruption file to assure that we have a traceable record for each data set.
- Every disruption analysis data set evaluated by the stress group should include or have added a side by side comparison of the OPERA filed and rate comparison along with the analysts results.

- Location of ANSYS Data Base; Analysis Scripts;
P:\public\Snap-srv\Bryant_Larry\NEUTRAL BEAM ARMOR CALCULATION

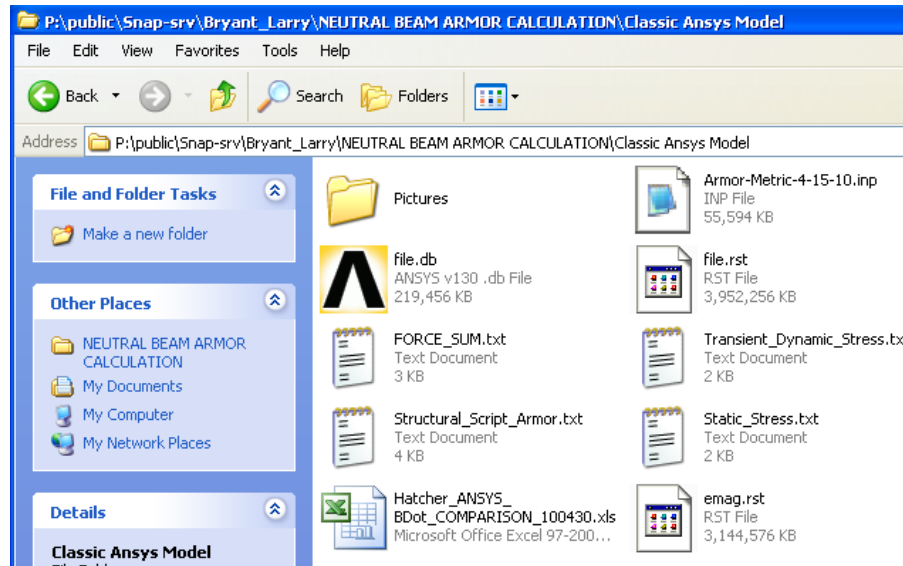

DATA FILES

– Location of Original Disruption files:

P:\public\Snap-srv\Bryant_Larry\NEUTRAL BEAM ARMOR CALCULATION\EMAG-SCRIPT-CHECK-5-13-10\DISRUPTION LOAD CASES

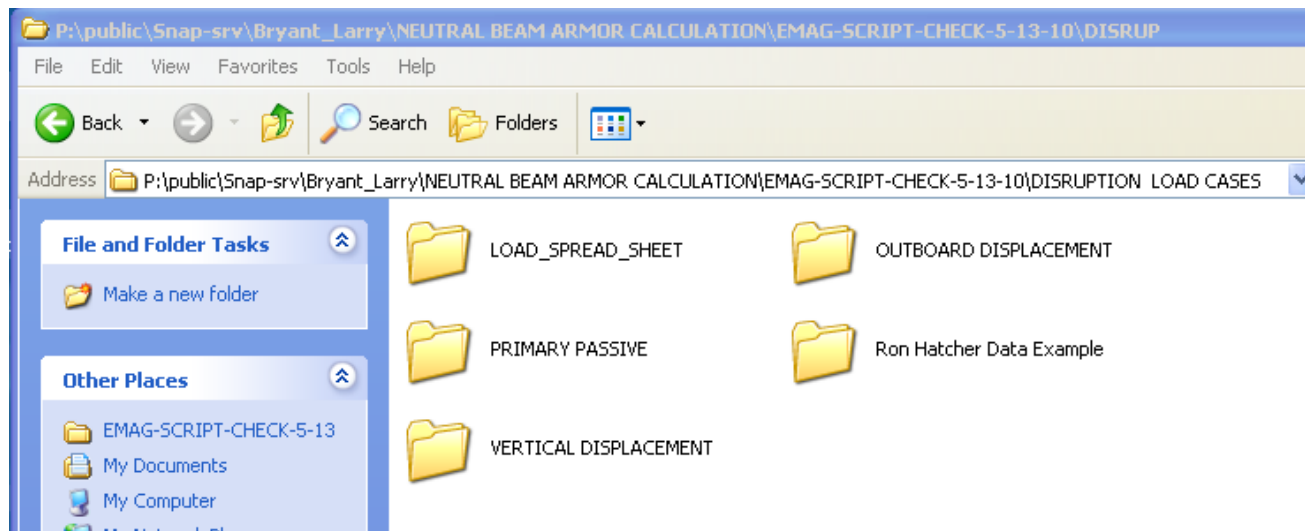

E-mail History

P:\public\Snap-srv\Bryant_Larry\NEUTRAL BEAM ARMOR CALCULATION\EMAG-SCRIPT-CHECK-5-13-10\E-mails on this subject

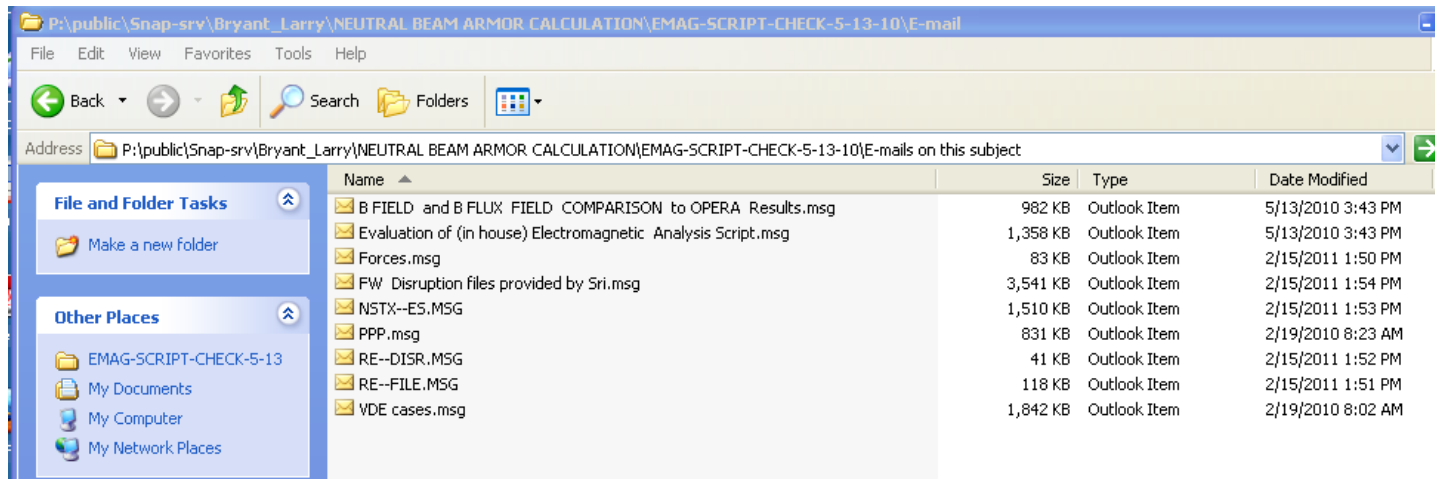

Name	Size	Type	Date Modified
B FIELD and B FLUX FIELD COMPARISON to OPERA Results.msg	982 KB	Outlook Item	5/13/2010 3:43 PM
Evaluation of (in house) Electromagnetic Analysis Script.msg	1,358 KB	Outlook Item	5/13/2010 3:43 PM
Forces.msg	83 KB	Outlook Item	2/15/2011 1:50 PM
FW Disruption files provided by Sri.msg	3,541 KB	Outlook Item	2/15/2011 1:54 PM
NSTX--ES.MSG	1,510 KB	Outlook Item	2/15/2011 1:53 PM
PPP.msg	831 KB	Outlook Item	2/19/2010 8:23 AM
RE--DISR.MSG	41 KB	Outlook Item	2/15/2011 1:52 PM
RE--FILE.MSG	118 KB	Outlook Item	2/15/2011 1:51 PM
VDE cases.msg	1,842 KB	Outlook Item	2/19/2010 8:02 AM